



The Global Language of Business

2D Barcodes at Retail Point-of-Sale Implementation Guideline

Release 1.0, Ratified, May 2024

Document Summary

Document Item	Current Value
Document Name	2D Barcodes at Retail Point-of-Sale Implementation Guideline
Document Date	May 2024
Document Version	1.0
Document Issue	
Document Status	Ratified
Document Description	

Log of Changes

Release	Date of Change	Changed By	Summary of Change
1.0	May 2024	Amber Walls (GS1 US) Dan Mullen (GS1 GO) Peta Ding (GS1 GO) Steven Keddie (GS1 GO)	Initial publication developed under GSMP Work Request 23-144

Disclaimer

GS1[®], under its IP Policy, seeks to avoid uncertainty regarding intellectual property claims by requiring the participants in the Work Group that developed this **2D Barcodes at Retail Point-of-Sale Implementation Guideline** to agree to grant to GS1 members a royalty-free licence or a RAND licence to Necessary Claims, as that term is defined in the GS1 IP Policy. Furthermore, attention is drawn to the possibility that an implementation of one or more features of this Specification may be the subject of a patent or other intellectual property right that does not involve a Necessary Claim. Any such patent or other intellectual property right is not subject to the licensing obligations of GS1. Moreover, the agreement to grant licences provided under the GS1 IP Policy does not include IP rights and any claims of third parties who were not participants in the Work Group.

Accordingly, GS1 recommends that any organisation developing an implementation designed to be in conformance with this Specification should determine whether there are any patents that may encompass a specific implementation that the organisation is developing in compliance with the Specification and whether a licence under a patent or other intellectual property right is needed. Such a determination of a need for licensing should be made in view of the details of the specific system designed by the organisation in consultation with their own patent counsel.

THIS DOCUMENT IS PROVIDED "AS IS" WITH NO WARRANTIES WHATSOEVER, INCLUDING ANY WARRANTY OF MERCHANTABILITY, NONINFRINGEMENT, FITNESS FOR PARTICULAR PURPOSE, OR ANY WARRANTY OTHERWISE ARISING OUT OF THIS DOCUMENT. GS1 disclaims all liability for any damages arising from use or misuse of this document, whether special, indirect, consequential, or compensatory damages, and including liability for infringement of any intellectual property rights, relating to use of information in or reliance upon this document.

GS1 retains the right to make changes to this document at any time, without notice. GS1 makes no warranty for the use of this document and assumes no responsibility for any errors which may appear in the document, nor does it make a commitment to update the information contained herein.

GS1 and the GS1 logo are registered trademarks of GS1 AISBL.

Table of Contents

1	Executive summary	6
1.1	The changing landscape of the retail industry	6
1.2	Ambition 2027	6
1.3	About this document	7
2	Background	8
2.1	Purpose	8
2.2	Scope	8
3	Terms, definitions, abbreviations and placeholders	9
3.1	Terms and definitions (Glossary)	9
3.2	Abbreviated terms	9
3.3	Placeholders	10
4	General guidance	10
4.1	Retail POS compliant barcodes	10
4.1.1	Retail barcodes options	11
4.1.2	Placement and multiple barcodes	11
4.1.3	Human readable text	12
4.2	Choosing the right barcode	14
4.2.1	Overview 2D barcode considerations	15
4.3	GTIN explanation	15
4.4	Barcode data beyond GTIN	17
4.4.1	Benefits of implementing GTIN with additional barcode data	17
4.4.2	GS1 Application Identifiers	18
4.4.3	Sharing of other types of data	20
4.5	GS1 barcode syntaxes used in retail POS	21
4.5.1	Using GS1 element string syntax	22
4.5.2	Benefits of using GS1 element string syntax in 2D barcodes	23
4.5.3	Using GS1 Digital Link URI syntax	24
4.5.4	Benefits of using GS1 Digital Link URI syntax in 2D barcodes	24
4.6	Optimising the 2D barcode size and data	25
4.6.1	Data and format considerations	26
4.6.2	Choose the right encoding strategy	27
4.6.3	Adjusting error correction level	28
4.6.4	Adjusting X-dimension and Quiet Zone	30
4.6.5	Use of images, colour and other modifications in 2D barcodes	30
4.7	Printing, reading and processing barcodes	33
4.7.1	Static vs. dynamic data	33
4.7.2	2D barcodes with static data	35
4.7.3	2D barcodes with dynamic data	36
4.7.4	2D barcode security	37
4.7.5	Resolver	38
5	Implementation guidance for brands and manufacturers	38
5.1	Brand manufacturer roles in 2D implementation	38
5.2	When to start transitioning to 2D barcodes	42

- 5.2.1 Common reasons to begin a transition to 2D barcodes 42
- 5.2.2 Determining which products to start with 42
- 5.3 Use case scenarios 43
 - 5.3.1 Consumer engagement and marketing opportunity use cases 43
 - 5.3.2 Packaging design constraints use cases 44
 - 5.3.3 Regulatory requirements and compliance use cases 45
 - 5.3.4 High-risk product category use cases 45
 - 5.3.5 Supply chain or retail need 46
 - 5.3.6 Sustainability and circularity activity use cases 47
 - 5.3.7 Transition from 2D barcodes not using GS1 standards 48
- 5.4 What goes into the barcode? 49
 - 5.4.1 GS1 Application Identifiers used in retail 49
- 5.5 Selecting which barcode to use 52
 - 5.5.1 Dual-marking with a linear and 2D barcode 53
- 5.6 Barcode placement and human readable text 54
 - 5.6.1 General examples 54
 - 5.6.2 2D barcode used for marketing purposes 56
 - 5.6.3 Placing barcodes on adjacent sides 57
 - 5.6.4 Fresh products 58
 - 5.6.5 Hang tags 58
 - 5.6.6 Large, heavy or bulky items 58
 - 5.6.7 Use of text or symbols to promote barcode interactions 59
 - 5.6.8 Where 2D barcodes cannot be used 59
- 5.7 Creating and printing 2D barcodes 60
 - 5.7.1 Barcode creation 60
 - 5.7.2 Barcode print quality and verification 61
 - 5.7.3 Dynamic data and barcode creation 61
 - 5.7.4 Barcode printing 62
- 5.8 Digital content creation and management 62

6 Implementation guidance for retailers 63

- 6.1 Transitioning to 2D Barcodes 64
 - 6.1.1 Steps for retailer 2D implementation 64
- 6.2 Product identification in retail 65
 - 6.2.1 Why GTIN is essential for product identification and retail operations 65
 - 6.2.2 Transition from Restricted Circulation Numbers (RCN) to GTIN 66
- 6.3 Retailer roles in 2D implementation 67
- 6.4 Retailer ecosystem 70
 - 6.4.1 Retail POS ecosystem 72
- 6.5 Staff and supplier communication and training 74
- 6.6 What goes into the barcode? 75
 - 6.6.1 Selecting data based on the use case 75
 - 6.6.2 Best practices for encoding data in 2D barcodes 82
- 6.7 Barcode placement and human readable text 83
- 6.8 Printing 2D barcodes 84
 - 6.8.1 Quality specifications 84
 - 6.8.2 Key factors to consider 84
 - 6.8.3 Testing and troubleshooting 86
- 6.9 Digital content creation and management 86



- 7 Implementation guidance for AIDC equipment and software companies.... 87**
 - 7.1 Solution provider role in 2D implementation 87
 - 7.1.1 Brand and manufacturer example 87
 - 7.1.2 Retailer example..... 89
 - 7.1.3 Stakeholders’ roles and responsibilities..... 90
 - 7.2 GS1 compliant retail barcodes 94
 - 7.2.1 Barcode Quality 94
 - 7.2.2 Barcode encoded data structures (syntaxes) 96
 - 7.2.3 Barcodes syntax resources..... 99
 - 7.2.4 Product data for barcode and HRI101
 - 7.3 2D barcode creation101
 - 7.3.1 2D barcode creation considerations.....102
 - 7.4 Printing.....102
 - 7.4.1 2D barcode printing considerations104
 - 7.5 Scanning.....105
 - 7.5.1 2D in retail barcode scanning considerations106
 - 7.5.2 2D in Retail scanning modes106
 - 7.5.3 2D in Retail scanners with limited capabilities.....108
 - 7.6 Verification.....108
 - 7.7 Point-of-sale (POS) host systems108
 - 7.7.1 2D in retail barcode POS host system considerations.....109
- 8 Appendix 109**
 - 8.1 Printers.....109
 - 8.1.1 Continuous Ink Jet (CIJ)109
 - 8.1.2 Thermal Ink Jet (TIJ)112
 - 8.1.3 Drop on Demand (DoD).....115
 - 8.1.4 Laser.....118
 - 8.1.5 Thermal transfer and direct thermal.....121
 - 8.1.6 Print and Apply (P&A).....123
 - 8.1.7 Digital printer.....127
 - 8.1.8 Printing summary129
 - 8.2 IP rating130
 - 8.3 2D barcode encoding modes.....130
 - 8.3.1 GS1 DataMatrix and Data Matrix (GS1 Digital Link URI) modes131
 - 8.3.2 QR Code (GS1 Digital Link URI) modes.....131
- 9 Contributors 132**
- 10 References 141**

1 Executive summary

This *2D Barcodes at Retail Point-of-Sale Implementation Guideline* is focused on the considerations and implications of utilising 2D barcodes encoded with GS1 barcode syntaxes at retail point-of-sale (POS) for brand owners, manufacturers, retailers and solution providers. The purpose of this document is to provide implementation guidance for industry to use in their 2D barcode journey and to enable a smooth, voluntary transition from linear barcodes, to using more capable 2D barcodes while minimising disruptions to existing business processes.

1.1 The changing landscape of the retail industry

To better enable the digital consumer and unlock current and emerging business use cases, such as sustainability and circular economies, the retail industry is embarking on one of the biggest changes since the original introduction of the EAN/UPC barcode: the adoption of 2D barcodes. 2D barcodes, like GS1 DataMatrix, Data Matrix or QR Codes, can be encoded with more data than the EAN/UPC linear barcode. Within these 2D barcodes, both additional data and links to web-enabled information can be included through the use of GS1 Digital Link URI in Data Matrix and QR Codes. Data might, for example, include the product’s expiry date, batch/lot number or serial number. Additionally, access to additional information on the web can include ingredient and allergen information, product pictures and videos, consumer reviews, recycling information services related to the product and more. Access to this additional information and data enhances the experiences of consumers, brands, retailers and everyone in between.

1.2 Ambition 2027

Industry has set the ambitious goal of transitioning from linear, 1D barcodes to more capable 2D barcodes on-pack. The initial goal is for retail point-of-sale (POS) scanning to be globally capable of reading and processing the GTIN from both existing linear and 2D barcodes by the end of 2027. The Ambition 2027 will require software upgrades and may require equipment upgrades if the POS scanner is not already imager capable. GS1 and industry are working together to support this migration and generate globally consistent guidance for business use cases. As there is no expectation that there will be a single 2D barcode selected for all industries, GS1 standards are enabling options that empower each industry to choose how they evolve towards more capable 2D barcodes while ensuring globally consistent implementations now and in the future. For example, in healthcare the journey towards 2D started in the early 2000s when industry chose GS1 DataMatrix as the single 2D barcode for product identification. Today there are billions of product packs with GS1 DataMatrix encoding the GS1 element string syntax. For healthcare products GS1 DataMatrix is the 2D barcode of choice for point-of-sale scanning. Linear barcodes (e.g., EAN/UPC and GS1 DataBar) will not go away and will coexist with 2D barcodes for as long as there are uses for them. During the dual-marking transition phase, the trade item will feature both the current linear (i.e., EAN/UPC or GS1 DataBar retail POS family) barcode and either a GS1 DataMatrix or QR Code with GS1 Digital Link URI syntax, or a Data Matrix with GS1 Digital Link URI syntax. For more information on the retail 2D barcode see Section 4.1. Figure 1-1 illustrates how to use a 2D barcode in addition to the linear barcode for companies and users who are ready to unlock opportunities enabled by 2D showing the minimum human readable interpretation (HRI) for retail.



Figure 1-1 2D barcode co-located transition

- ✓ **Note:** Once 2D barcodes at POS have achieved pervasive adoption, brand owners and manufacturers can choose to use only the 2D barcode, continue with the retail POS linear barcode in combination with the 2D barcode or stay with only the POS linear barcode.
- ✓ **Note:** Not all imaging scanners will be capable of the Ambition 2027 goal, therefore collaborating with the point-of-sale solution provider will be essential for accepting 2D barcodes at POS. See Section [7.5.1](#) 2D in retail barcode scanning considerations for more information.

For further information, contact your local [GS1 Member Organisation](#).

1.3 About this document

This is a practical implementation guideline for brands, manufacturers, retailers, suppliers, distributors, warehouse operators and solution providers to understand business opportunities, process changes and requirements needed to implement GTIN, GS1 Application Identifiers (AIs), GS1 DataMatrix, GS1 Digital Link URI syntax in QR Code or Data Matrix and linear barcodes at point-of-sale (POS) and in manufacture of trade items.

All barcode examples in this document, are shown for illustrative purposes only and may not represent the sizes approved for use in the GS1 General Specifications. The Symbol Specifications Tables defined by the GS1 General Specifications SHALL be used for all normative references to ensure conformance requirements are met.

This document includes information designed to help companies plan for 2D implementations. Sections 2 through 4 are focused on **definitions and explanations**, including:

- Retail POS barcodes
- Choosing the right barcode
- Benefits of GTIN and additional data
- GS1 barcode structures

All readers are advised to read Section 4 for general guidance.

- **New users:** If GS1 standards are new to your company, please contact your local GS1 Member Organisation (www.gs1.org/contact).
- **Brands and manufacturers:** Read Section [5](#) for business process changes required to implement GTIN, GS1 Application Identifiers, GS1 barcode syntaxes and conformant GS1 barcodes at point-of-sale. Read Section [7](#) for guidance on enabling 2D capability within a brand and manufacturer's ecosystem.
- **Retailers:** Read Section [6](#) for business process changes required to implement GTIN, GS1 Application Identifiers, GS1 barcode syntaxes and conformant GS1 barcodes at point-of-sale. Read Section [5](#) for own-brand/private label guidance and Section [7](#) for guidance on enabling 2D capability within a retailer ecosystem.
- **AIDC equipment and software companies:** Read Section [7](#) and [8](#) for requirements to implement GTIN, GS1 Application Identifiers, GS1 barcode syntaxes and relevant GS1 barcodes at point-of-sale.

Sections [5](#) through [8](#) are focused on **implementation guidance** for manufacturers and brand owners, retailers, distributors, warehouse operators and solution providers. While the information provided is not intended to enable a complete 2D implementation across a company, it can be used as a resource alongside the GS1 General Specifications, with guidance from local Member Organisations for companies to reference along their journey.

The final appendix sections focus on information to successfully print 2D barcodes during the transition period until the required capabilities are achieved.

2 Background

The Universal Product Code barcode (UPC-A and UPC-E) and European Article Number barcode (EAN-13 and EAN-8) have been trusted and ubiquitous data carriers for facilitating the price look-up function at retail point-of-sale (POS) since the early 1970s. This innovation automated a critical business process for retail POS everywhere.

The EAN/UPC family of barcodes carries only the Global Trade Item Number® (GTIN®) associated with a product. Due to this data capacity limitation, the GS1 DataBar Expanded barcodes were introduced to meet business requirements for more data, such as batch/lot number and expiration date. However, GS1DataBar Expanded barcodes still have limited data capacity, and can become too large to fit on many packages. As linear barcodes require a mobile device app to access online information, they are not as consumer friendly as other data carriers, such as QR Codes, that allow consumers and business users alike to access additional product data and online information more directly.

The momentum for change, to use more capable 2D barcodes, is driven by industry's need to encode more data on-pack and to allow consumer engagement through links to web-enabled information. This meets the growing information demands of consumers and regulators, enables additional supply chain efficiencies, creates new circular economies and builds brand trust by providing more accurate, complete and up-to-date product information, all the while enabling existing POS processes.

2.1 Purpose

The purpose of this document is to provide implementation guidance for industry beginning their 2D barcode journey and to enable a smooth, voluntary transition from using linear barcodes to using more capable 2D barcodes while minimising disruptions to existing business processes. This *2D Barcodes at Retail Point-of-Sale Implementation Guideline* is focused primarily on the considerations and implications of utilising 2D barcodes encoded with interoperable GS1 data and syntaxes at point-of-sale (POS).

This document is expected to expand over time based on growing user implementations and as the standards are updated.

2.2 Scope

In Scope	Out of Scope
<ul style="list-style-type: none"> ▪ Guidance for retailers, brand owners, manufacturers and solution providers ▪ Any consumer units scanned at retail POS ▪ Guidance on how to use GS1 DataMatrix, Data Matrix and QR Code at POS* ▪ Encoding GTIN + data attributes using GS1 element string syntax and GS1 Digital Link URI (Uniform Resource Identifier) syntax ▪ Dual-marking: Linear + 2D barcodes ▪ Retail and consumer use cases unlocked with 2D barcodes ▪ 2D barcode printing including barcode quality, reading (scanning) and processing considerations for manufacturing and retail POS 	<ul style="list-style-type: none"> ▪ Radio Frequency Identification (RFID) usage for retail POS (see EPC/RFID standards for more information)** ▪ Guidance to meet the requirements of specific regulations*** ▪ Industry or product type specific guidance ▪ Non-consumer units and packaging hierarchies scanned in distribution and non-retail environments ▪ Non-GTIN solutions (Restricted Circulation Numbers [RCN], proprietary encoding, etc.) ▪ Data sharing methods (e.g., master data, event data, transactional data, web standard)

* While point-of-sale (POS) is mainly referred to as being enabled by fixed or hand-held scanners at the front of the store, retail POS can happen in multiple locations and ways, including utilising scanners in POS lanes, at self-checkout or using mobile devices on the sales floor and the backroom.

** RFID data carriers that use GS1 standards are seeing increasing use in supply chain to improve inventory management – especially in the apparel sector – they will not be addressed in this document. For more information on RFID, see [EPC/RFID standards and guidance](#).

*** This *2D Barcodes at Retail Point-of-Sale Implementation Guideline* is not an exhaustive implementation guideline for all regulated healthcare uses cases for GS1 DataMatrix. It includes guidance for healthcare products intended to be scanned at point-of-sale. For details on the use of GS1 DataMatrix for regulated healthcare products, see the [GS1 DataMatrix Position Paper](#). A full list of global GS1 healthcare position papers can be found at <https://www.gs1.org/industries/healthcare/position-papers>.



Important: Products may exist in multiple channels (e.g., retail and foodservice, clinical healthcare settings). This document only addresses scanning at POS in retail channels.

3 Terms, definitions, abbreviations and placeholders

3.1 Terms and definitions (Glossary)

Please refer to the www.gs1.org/glossary for the latest version.

Table 3-1 Key terms and definitions utilised in this document

Term	Definition
dynamic data	Information that can change or be updated in real-time or based on specific conditions, such as serial number.
GS1 compliant barcodes	Barcodes in the GS1 system that meet the syntax and barcode specifications defined by GS1 standards.
GS1 barcode syntax	A data structure used within the GS1 system of standards for representing data elements in barcodes, which includes plain syntax, GS1 element string and GS1 Digital Link URI.
host system	the central software or hardware platform that manages and controls transactions at a point-of-sale location.
linear barcode	barcode symbology using bars and spaces in one dimension, sometimes referred to as 1D barcode.
point-of-sale (POS) solutions	hardware and software components that facilitate the processing of sales transactions, such as scanning and weighing products, processing payments, and generating receipts.
static data	information that remains constant, for example the GTIN is product information that is unchanging and remains the same in the barcode data.
variable data	information that can vary or change from one instance to another within a dataset or a set of records, such as batch number.
verifier	in the context of barcoding and quality control, refers to a measuring device used to analyse various aspects of barcode quality according to industry standards and specifications. This is often known as a barcode verifier.

3.2 Abbreviated terms

Table 3-2 Abbreviations utilised in this document

Abbreviation	Term
AI	GS1 Application Identifier
API	Application programming interface
AIDC	Automatic identification and data capture
CIJ	Continuous ink jet
DOD	Drop on demand

Abbreviation	Term
ERP	Enterprise resource planning
LASER	Light amplification by stimulated emission of radiation
POS	Point-of-sale
RCN	Restricted Circulation Number
TIJ	Thermal ink jet
TT	Thermal transfer

3.3 Placeholders

A placeholder serves as a temporary word or symbol until actual data is provided in the application.

Table 3-3 Placeholders utilised in this document

Placeholder	Description
example.com	The example.com domain name is used as an example only within this document for URLs and QR Codes and are not intended to be active links. A GS1 Digital Link URI can be based on any internet domain name. GS1 recommends brand owners use their own domain name in the GS1 Digital Link URI.
^	The "^" is a placeholder for the unprintable hex 1D (Group Separator) or Function 1 (FNC1) symbol characters.

4 General guidance

This section provides information that may be used by any retail sector stakeholder looking to implement 2D barcodes and assumes a basic understanding of the GS1 system. Before beginning implementation of 2D barcodes or additional data capture, it is highly recommended that stakeholders gain an initial understanding of the GS1 system of standards related to product identification and data capture, by working with their local GS1 Member Organisation (www.gs1.org/contact).

For further education on GS1 standards, see [GS1 General Specifications](#), [GS1 two-dimensional \(2D\) barcodes](#), [GS1 DataMatrix Guideline](#), [GS1 Digital Link URI Standard](#) and [The key role of GS1 DataMatrix barcodes for product identification in healthcare](#).

4.1 Retail POS compliant barcodes

Retailers, brands, solution providers and GS1 collaborated to reach consensus on the future of barcodes in retail. The resulting GS1 barcode standards and guidance provide the size, quality, placement, syntax and human readable text criteria for 2D barcodes used on retail consumer trade items scanned at point-of-sale (POS).

While the POS linear barcode is not going away, 2D barcodes cannot immediately be the only barcode on-pack until ubiquitous global scanning of 2D barcodes is achieved. Therefore, industry needs a transition period. The new standards and Ambition 2027 allow retailers and other parties throughout the supply chain time to plan for being able to scan and process different barcodes through their POS and facilities. With planning, this will ensure the ability to support the evolution of existing systems to unlock these additional capabilities by 2027.

Until 90% of POS scanning solutions are capable of using GS1 compliant POS 2D barcodes and at minimum capture the GTIN, any products using retail 2D barcodes on-pack will need to be accompanied by a POS linear barcode.

4.1.1 Retail barcodes options

The point-of-sale (POS) linear barcode choices include the EAN/UPC and GS1 DataBar POS family of barcodes.



Figure 4-1 Example of POS linear barcodes

The POS 2D barcode choices, for future state implementations including the transition period, are the QR Code with GS1 Digital Link URI syntax, Data Matrix with GS1 Digital Link URI syntax and GS1 DataMatrix.

QR Code (GS1 Digital Link URI)



(01)09524810000339

GS1 DataMatrix



(01)09524810000339

Figure 4-2 Example of POS 2D barcodes

! **Important:** Once 2D barcodes at POS have achieved pervasive adoption the brand owner can choose to use only the 2D barcode, continue with the retail POS linear barcode in combination with the 2D barcode or stay with only the POS linear barcode.

The [GS1 General Specifications](#) has a section devoted to Application Standard Profiles (ASP) that helps navigate adopting 2D barcodes. The ASPs provide an overview of what is conformant for current and future state implementations to facilitate the transition period. These ASPs are designed for all stakeholders involved in the implementation process to access the application standards, barcode choices, barcode standards (e.g., ISO specifications, X-dimension, size, quality specifications), barcode syntaxes and more.

4.1.2 Placement and multiple barcodes

Placement of 2D barcodes and the rules for multiple barcodes on-pack are critical to ensure POS remains efficient. Without these rules, high speed retail point-of-sale (POS) may be unable to meet their productivity target rate of 40 to 70 items per minute (IPM). Section 4.15 of the [GS1 General Specifications](#) provides a set of barcode management practices intended to permit the use of multiple barcodes on the same trade item. This includes rules for adjacent and non-adjacent placement and rules for the transition to 2D barcodes. Also see Section [5.5.1](#) Dual-marking with a linear and 2D barcode.

In parallel, several POS scanner solution providers have developed software for some models of their POS solutions to manage multiple barcodes on-pack. Their new software can decode multiple barcodes and deliver the encoded data from barcodes leveraging GS1 identification, as well as delivering the information as a GS1 element string syntax to the host POS system. This is important

for situations when a barcode with GS1 Digital Link URI is identified, because translating the URI syntax to a GS1 element string syntax eliminates the need to upgrade the host POS system to scan GS1 Digital Link URI syntax. However, to achieve the 40 to 70 IPM target, the placement of linear and 2D barcodes relative to each other needed to be determined through extensive lab testing. See also [2D in Retail co-located test results](#) for details.

- ✔ **Important:** Not all POS solutions are capable of processing GS1 compliant 2D barcodes at this time. It is best to contact the solution provider to confirm capabilities on specific POS solutions.



Figure 4-3 2D barcode placement in relation to the linear barcode

Extensive, independent testing showed that the 2D barcode needs to be within 50 mm of the linear barcode's centre to achieve the target retail IPM. To learn more about barcode placement rules see Section 6 of the [GS1 General Specification](#).

The human readable text, both human readable interpretation (HRI) and/or non-HRI text, placement is an integral part of the placement considerations see Section [4.1.3](#) and the HRI rules for retail consumer trade items are detailed in Section 4.15 of the [GS1 General Specification](#).

4.1.3 Human readable text

Human readable text is used to describe both human readable interpretation (HRI) and/or non-HRI text relating to the barcode collectively, when referencing data that is encoded into a data carrier. HRI represents the same data encoded in the barcode. Non-HRI text is all other text on the product packaging which may or may not be encoded in the barcode. If the barcode fails to scan at the retail POS, a combination of HRI and non-HRI text can be used to complete the transaction.

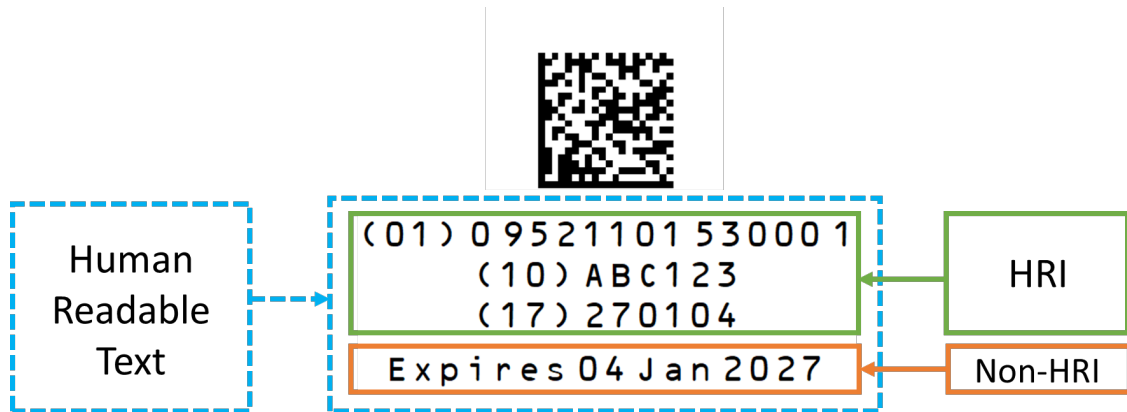

Figure 4-4 Human readable text

Human readable text requirements are dependent primarily on the following factors:

- Type and purpose of barcode
- Adjacency of the multiple barcodes
- Presence of existing HRI
- If the 2D barcode and encoded data are intended for retail POS, consumer engagement applications or internal use only

For example, in Figure 4-5, both QR Codes are identical, with the exact same GS1 Digital Link URI syntax encoded. The QR Code on the front panel does not require HRI as the brand owner intends the 2D barcode to be used for online consumer information. The QR Code on the back panel also does not require HRI as it is adjacent to an EAN-13 that has the HRI.



Figure 4-5 Example of consumer engagement and retail POS barcodes

In the future, when the 2D barcode is the only barcode on the object, the 14-digit GTIN HRI will be required, as seen in Figure 4-6.

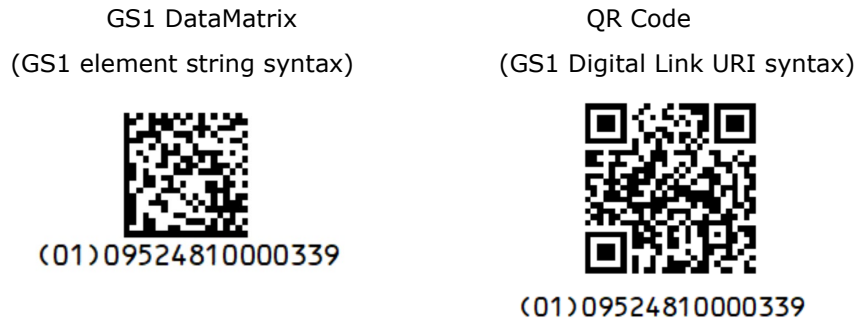

Figure 4-6 Example of GTIN-13 in 14-digit format

The HRI rules for retail consumer trade items are detailed in Section 4.15 of the [GS1 General Specification](#) and include examples of multiple barcodes on the same object. Section 5.6 of this guideline provides additional examples of barcode placement and human readable text.

4.2 Choosing the right barcode

Determining which 2D barcode is best to use is dependent on what use cases need to be enabled and a variety of other factors.

To move forward, communication between all impacted stakeholders, including stakeholders internal to each organisation, is essential to ensure solutions are interoperable. For next steps, GS1 recommends considering how to ensure the path forward is **collaborative** and the solutions are **capable** and **compliant**. Consider the following when determining what barcode to move forward with:

Is the barcode capable of being produced and used where intended?

- Is the barcode capable of encoding a GS1 barcode syntax (i.e., plain, GS1 element strings, GS1 Digital Link URI) and approved for use on retail trade items?
- Can the barcode be created and/or applied at the speed and quality required for the use case?
- Are those intended to interact with the barcode able to process it consistently (e.g. are the back office/receiving systems ready for additional data)?
- Are barcodes produced to be conformant to the *GS1 General Specifications*?

Is the barcode compliant with requirements?

- Is there a regulatory requirement?
- Is there a liability disclosure requirement to the consumer and/or trading partner?
- Is the barcode approved for use in the GS1 standards for open global use via an application standard and meets all GS1 policy requirements?
- Does your industry have an agreement to use a specific type of 2D barcode (e.g., healthcare and GS1 DataMatrix)?



Note: For details on the use of GS1 DataMatrix for regulated healthcare products, see the [GS1 DataMatrix Position Paper](#). A full list of global GS1 healthcare position papers can be found at <https://www.gs1.org/industries/healthcare/position-papers>.

Has the barcode decision process been collaborative?

- Have all internal and external stakeholders been brought together to enable the transition to the future solution? Such stakeholders may include:
 - Industry/trading partners
 - Solution partners (label designer, printing, scanning, data storing, data processing)

- Local GS1 Member Organisation
- Have the stakeholders considered the data, data carrier, packaging, scanning hardware/software, and receiving systems' needs and existing capabilities?

Each section of this document encapsulates these guiding principles, including detailing the stakeholder for collaboration, referencing solution capabilities and compliance.

For more information see the [GS1 2D in retail barcodes explorer](#).

4.2.1 Overview 2D barcode considerations

Throughout this guideline, additional details will be given to support determining which 2D barcode will be best suited for different scenarios. The following is a high-level summary of key points and is not an exhaustive list.

Table 4-1 2D barcode considerations

	GS1 DataMatrix	QR Code (GS1 Digital Link URI)	Data Matrix (GS1 Digital Link URI)
GS1 barcode syntax	GS1 element string	GS1 Digital Link URI	GS1 Digital Link URI
Connect to digital content	Requires specialised mobile device app	Consumer scannable with mobile device's default camera app	Requires specialised mobile device app
Connect to richer and tailored experiences	Requires specialised mobile device app	Can be offered as a links page, or may require a specialised mobile device app and use of a GS1-conformant resolver	Requires specialised mobile device app
Size on packaging	Smallest size (of POS compliant 2D)	Larger size (of POS compliant 2D)	Small size
Healthcare	Globally approved for regulated healthcare product	Not applicable to healthcare	Not applicable to healthcare
Fresh foods	Simple switch from EAN/UPC or GS1 DataBar; or transition from RCN to GTIN	New for fresh	New for fresh
Ability to scan using imaging scanners	Capability available, may only need to be enabled	Software upgrade required to enable POS scanners	Software upgrade required to enable POS scanners

! **Important:** Much like transitioning from linear to 2D barcodes, it is possible to change between 2D barcode types and change the type of data included in the barcode as use cases evolve. While it may be ideal to only change the barcode being used once, it can change more over time based on use case needs. Once updated, retailer systems will be able to read GS1 DataMatrix with GS1 element string syntax and QR Code with GS1 Digital Link URI syntax and Data Matrix with GS1 Digital Link URI syntax.

4.3 GTIN explanation

A Global Trade Item Number (GTIN), is the GS1 standard for unique identification of products and services, known as trade items. The GTIN is globally used in barcodes to enable the accurate identification of items throughout supply chains and in post-purchase activities.

GTINs are widely used in various industries, such as retail, healthcare, manufacturing, logistics and e-commerce, to uniquely identify products and facilitate efficient inventory management and product tracking. In retail, GTIN can be encoded in different barcode symbologies, including UPC

(Universal Product Code), EAN (European Article Number), GS1 DataBar retail POS family, GS1 DataMatrix, Data Matrix with GS1 Digital Link URI syntax and QR Code with GS1 Digital Link URI syntax.

During the dual-marking transition phase, the trade item will feature both the current EAN/UPC barcode and either a GS1 DataMatrix or QR Code with GS1 Digital Link URI syntax or a Data Matrix with GS1 Digital Link URI syntax.

- ✔ **Note:** Book, serial publications and music numbering systems use the International Standard Book Number (ISBN), International Standard Serial Number (ISSN) and International Standard Music Numbers (ISMN) system, respectively, which are compatible with GTIN-13 and can be encoded in EAN/UPC family of barcodes.

Which GTIN can be used and the structure of that GTIN varies based on the barcode symbology. For example, a GTIN-13 is encoded into the EAN-13, while GTIN-12 is encoded in the UPC-A. For more guidance on GTINs, see the [GS1 General Specifications](#) and [GTIN Management Standard](#).



Figure 4-7 EAN-13 and UPC-A

GS1 DataBar retail POS family, GS1 DataMatrix, QR Code with Digital Link URI syntax and Data Matrix with GS1 Digital Link URI syntax use the zero padded, 14-digit format of GTIN-13, GTIN-12 and GTIN-8. When any of these GTINs are encoded in a data carrier that must encode a fixed-length data string of 14-digits, the GTINs less than 14 digits must be prefixed by leading zeroes that act as filler digits, see Figure 4-8.

- ! **Important:** All retail systems interacting with GTINs must be able to interact with GTIN-13, GTIN-12 and GTIN-8. For more information, contact your local GS1 Member Organisation.

GTIN	Global Trade Item Number (GTIN) Field													
-	N ₁	N ₂	N ₃	N ₄	N ₅	N ₆	N ₇	N ₈	N ₉	N ₁₀	N ₁₁	N ₁₂	N ₁₃	N ₁₄
GTIN-8	0	0	0	0	0	0	D ₁	D ₂	D ₃	D ₄	D ₅	D ₆	D ₇	D ₈
GTIN-12	0	0	D ₁	D ₂	D ₃	D ₄	D ₅	D ₆	D ₇	D ₈	D ₉	D ₁₀	D ₁₁	D ₁₂
GTIN-13	0	D ₁	D ₂	D ₃	D ₄	D ₅	D ₆	D ₇	D ₈	D ₉	D ₁₀	D ₁₁	D ₁₂	D ₁₃
GTIN-14	D ₁	D ₂	D ₃	D ₄	D ₅	D ₆	D ₇	D ₈	D ₉	D ₁₀	D ₁₁	D ₁₂	D ₁₃	D ₁₄

Figure 4-8 GTIN structures

- 'N' represents the digit placement in an application, database or barcode that require a 14-digit format.
- 'D' represents the digit allocated for each position of the GTIN.

- The GTIN-13, GTIN-12 and GTIN-8 structures are right-justified and zero padded with leading zeroes '0' serving as filler digits to complete the required 14-digit format.

! **Important:** GTIN-14 cannot be used to identify trade items sold at retail POS and are not in scope for this implementation guideline. For more guidance on GTIN-14 and its uses, see the [GS1 General Specifications](#) and [GTIN Management Standard](#).

Table 4-2 GTIN structures in retail (*)

Barcode symbology	GTIN options for retail	GTIN structure in barcode
EAN-13	GTIN-13	13-digit: 9521101530001
UPC-A	GTIN-12	12-digit: 012345000058
EAN-8	GTIN-8	8-digit: 95200002
UPC-E	GTIN-12	8-digit: 01234558
GS1 DataBar retail POS family	GTIN-8, GTIN-12, GTIN-13	14-digit: <ul style="list-style-type: none"> ■ GTIN-8: 00000095200002 ■ GTIN-12: 00012345000058 ■ GTIN-13: 09521101530001
GS1 DataMatrix	GTIN-8, GTIN-12, GTIN-13	
QR Code (GS1 Digital Link URI)	GTIN-8, GTIN-12, GTIN-13	
Data Matrix (GS1 Digital Link URI)	GTIN-8, GTIN-12, GTIN-13	

(*) See [GS1 General Specifications](#) for application and GTIN rules for retail

4.4 Barcode data beyond GTIN

The GTIN uniquely identifies a trade item by serving as its means of primary identification. Sometimes, there is a need to provide additional information beyond the GTIN. Using data beyond the GTIN provides more granular and detailed information about a product and can include data elements such as batch/lot number, serial number and expiration date. GS1 element string and GS1 Digital Link URI are the two GS1 barcode syntaxes that enable the use of additional data in barcodes, see Section 4.5 for more information on syntaxes. Depending on the needs of each use case, the additional data may need to be scanned, processed, stored and used in the POS system. To use the additional data, systems may need to be upgraded. The implications for both hardware and software will be explored in this guideline.

4.4.1 Benefits of implementing GTIN with additional barcode data

Consumers are demanding access to more information both online and on product labels and they expect retailers and regulators to protect them from purchasing expired, counterfeit, or unsafe products.

Along with these consumer needs, retailers and suppliers also benefit from increased supply chain visibility, enhanced recall readiness abilities and improved sales data.

Encoding additional data to support the GTIN in the barcode can make this possible, as it enables automation and validation information throughout the supply chain and at the point-of-sale (POS). This data can, for example, include weight, best before date, lot/batch number and serial number. Further details on additional data options and their implications for printing, scanning and utilisation are elaborated upon in Sections 5, 6, and 7.

Implementing GTIN with additional data about the item can support the following business use cases and more:

- Consumer and food safety programs at the register and on the consumer receipt
- Improved quality control of products on the shelf
- Food waste prevention/management

- Expiration date management. For example, by encoding the product's expiry date, it becomes possible to automatically prevent the sale of out-of-date products at the POS
- Global or regional traceability initiatives and more effective targeted recalls
- Category/promotional management
- Inventory replenishment and reduced out of stocks
- Returns management
- Improved pricing accuracy at POS (e.g., automatic price mark-downs based on date)
- Global or regional regulatory compliance
- Product authentication and anti-counterfeit

4.4.2 GS1 Application Identifiers

A GS1 Application Identifier (AI) is a numeric code of two or more digits that uniquely defines the format and meaning of the information that follows the AI. AIs enable several pieces of data to be encoded in one barcode and so the information can be interpreted and processed correctly and consistently. GS1 element string or GS1 Digital Link URI syntaxes enable the use of GTIN and additional data in barcodes. Which AIs to use will be determined based on the targeted use case.

 **Note:** Not all GS1 Application Identifiers will be enabled across all retailers. Which AIs are available and able to be used can vary based on where it is being read.

 **Important:** To aid readability within the body text of this guideline, AIs are displayed in round brackets following their text description, e.g., serial number (21).

Table 4-3 contains the AIs that are often used to support retail applications.

Table 4-3 Common GS1 Application Identifiers

AI	Data Content	Format*	Data Title
01	Global Trade Item Number (GTIN)	N2+N14	GTIN
10	Batch or Lot Number	N2+X..20	BATCH/LOT
11 (**)	Production Date (YYMMDD)	N2+N6	PROD DATE
13 (**)	Packaging Date (YYMMDD)	N2+N6	PACK DATE
15 (**)	Best Before Date (YYMMDD)	N2+N6	BEST BEFORE or BEST BY
17 (**)	Expiration Date (YYMMDD)	N2+N6	USE BY OR EXPIRY
21	Serial Number	N2+X..20	SERIAL
22	Consumer product variant	N2+X..20	CPV
240	Additional product identification assigned by the manufacturer	N3+X..30	ADDITIONAL ID
241	Customer part number	N3+X..30	CUST. PART No.
243	Packaging component number	N3+X..20	PCN
30	Count of Items (Variable Measure Trade Item)	N2+N..8	VAR. COUNT
310n (***)	Net weight, kilograms (Variable Measure Trade Item)	N4+N6	NET WEIGHT (kg)
320n (***)	Net weight, pounds (Variable Measure Trade Item)	N4+N6	NET WEIGHT (lb)
392n (***)	Applicable Amount Payable, single monetary area (Variable Measure Trade Item)	N4+N..15	PRICE

AI	Data Content	Format*	Data Title
393n (***)	Applicable Amount Payable with ISO Currency Code (Variable Measure Trade Item)	N4+N3+N..15	PRICE
395n (***)	Amount payable per unit of measure single monetary area (variable measure trade item)	N4+N6	PRICE/UoM
422	Country of Origin	N3+N3	ORIGIN
7003	Expiration date and time	N4+N10	EXPIRY TIME
8008	Date and Time of Production	N4+N8+N..4	PROD TIME

- * Technical details about format and separator character requirements can be found in the GS1 General Specifications
- ** If only year and month are available, DD must be filled with two zeroes. As of 1 January 2025, all regulated healthcare products using the GS1 Application Identifiers for expiration date or production date in their barcode require a valid day of the month (i.e., 01-31).
- *** The fourth digit of this GS1 Application Identifier indicates the implied decimal point position. Example: 3103 Net weight in kilograms with three decimal points

Figure 4-9 shows how data could be structured using GS1 element string syntax for variable measure trade items sold at POS. The same data is encoded in the GS1 DataBar Expanded Stacked and the GS1 DataMatrix, for illustrative purposes.



Figure 4-9 GS1 Application Identifier example with GS1 element string

(01)09512345678901(3103)001015(17)271231(3922)1655(10)ABC123

- **(01)** Global Trade Item Number – 09512345678901
- **(3103)** Net weight, kg – 1.015 kg
- **(17)** Expiration date – 31 December 2027
- **(3922)** Price to pay - \$16.55
- **(10)** Batch or lot number – ABC123

Figure 4-10 shows how data could be structured using GS1 Digital Link URI syntax for fixed measure trade items sold at POS. The data is encoded in a QR Code with GS1 Digital Link URI syntax, for illustrative purposes.



(01)09506000134352

Figure 4-10 GS1 Application Identifier example with GS1 Digital Link URI

<https://example.com/01/09506000134352/22/73/10/ABC?11=230718>

- **(01)** Global Trade Item Number – 09506000134352
- **(22)** Consumer product variant – 73
- **(10)** Batch or lot number – ABC
- **(11)** Production date – 18 July 2023

See Section [4.5](#) for an overview of GS1 barcode syntaxes, including the GS1 Digital Link URI syntax.

4.4.3 Sharing of other types of data

The core reason to use any data carrier, 2D barcodes included, is to identify a physical object and key details about it as it moves through its lifecycle and connect it with digital information. In the case of products, the unique Global Trade Item Number (GTIN) is used to tie together the physical and digital information. When coupled with additional identification elements, like consumer product variant, batch/lot number and/or serial number, more exact, detailed information can become available.

The digital information tied to a GTIN is initiated long before the physical product is produced and will remain long after the product's lifecycle ends. This digital information addresses needs beyond what barcodes can do alone. If looking to share information beyond what is in the barcode or linked to via the barcode, refer to additional GS1 standards and guidelines.

■ **Product data sharing**

2D barcodes are an enabler to access and unlock further data and data sharing related standards and services, such as:

- [GS1 Global Data Model](#) (GDM): The GDM clarifies data requirements across trading partners by defining the attributes needed to list and sell a product in a given market.
- [GS1 Global Data Synchronisation Network](#) (GDSN): The GDSN is the world's largest product data network. Here, standardised product content is uploaded, maintained and shared automatically, ensuring trading partners have immediate access to the most current and complete information needed to exchange products on both local and global markets.
- [Verified by GS1](#): With the Verified by GS1 service, users can verify the identity and ownership of any GS1 identifier, product, company and location, based on basic data provided by the data owner that can be accessed openly and globally.
- [GS1 Web Vocabulary](#): The GS1 Web Vocabulary makes it easier to include detailed structured data about a product for a web page using a standard vocabulary. The structured data about the product can then be used by search engines, mobile device apps, etc. to deliver a richer experience to the consumer.
- **Transactional data sharing** with GS1 [Electronic Data Interchange](#) (EDI): EDI provides global standards for electronic business messaging that allow automation of business transactions commonly occurring across the entire supply chain. Users in North America use the X-12 standard for EDI and can contact their local MO to learn about EDI requirements in their region

- **Visibility data sharing** with [Electronic Product Code Information Services \(EPCIS\)](#): EPCIS is a data sharing standard for enabling visibility, within organisations as well as across an entire supply chain of trading partners and other stakeholders. It helps provide the “what, when, where, why and how” of products and other assets, enabling the capture and sharing of interoperable information about status, location, movement and chain of custody.

4.5 GS1 barcode syntaxes used in retail POS

GS1 has three syntaxes suitable for encoding in barcodes scanned at retail point-of-sale (POS):

- **Plain syntax:** GS1 data structure containing a GS1 identification key with no additional characters or syntactic features. This format is used for EAN/UPC family barcodes, where only a GTIN is to be encoded, without any GS1 Application Identifiers (AIs) or any other data. For example, a GTIN-13 appears in plain syntax as 9526064055028.



Figure 4-11 EAN-13

- **GS1 element string syntax:** a syntax for expressing GS1 identification keys and other data using GS1 Application Identifiers (AIs). In the human readable text associated with the barcode, AIs are surrounded by parentheses to aid readability and support input or display within user interfaces (e.g., barcode generator software). Parentheses are never encoded directly to the barcode. For information on how the human readable text associated to the barcode is displayed, see Section [4.1.3](#).

For example, not including non-keyboard characters like FNC1, a GTIN, expiration date, batch/lot number and serial number, using GS1 element string syntax, would be encoded into the barcode as 01095260640550281725052110ABC12321345DEF.



(01)09526064055028(17)250521(10)ABC123(21)345DEF

Figure 4-12 GS1 DataMatrix

- **GS1 Digital Link URI syntax:** a web URI syntax for expressing GS1 identification keys and other data in a format using GS1 Application Identifiers (AIs) as specified in the GS1 Digital Link URI standard. GS1 Digital link URI incorporates elements of existing web standards, such as domain name, that allow the barcode to connect users to the web. For example, a domain name, a GTIN, expiration date, batch/lot number and serial number using GS1 Digital Link URI syntax would be encoded into the barcode as: <https://example.com/01/09526064055028/10/ABC123/21/345DEF?17=250521>. For information on how the human readable text associated to the barcode is displayed, see Section [4.1.3](#).

- The “example.com” domain name is used as an example only. A GS1 Digital Link URI can be based on any internet domain name. GS1 recommends brand owners use their own domain name in the GS1 Digital Link URI.



<https://example.com/01/09526064055028/10/ABC123/21/345DEF?17=250521>

Figure 4-13 QR Code (GS1 Digital Link URI)

The figure below provides a summary of the barcode and syntax options that can be used at retail POS as outlined above, noting where data beyond GTIN is supported in the GTIN attribute column and which device types can support decoding.

For further information on GS1 standards, see Section [7.2.2](#) for barcode encoded data structures (syntaxes), [Best practices for creating your QR Code powered by GS1](#), [GS1 General Specifications](#) and [GS1 Digital Link URI Standard](#).

Table 4-4 Retail barcode syntax comparison

Barcode	Syntax	GTIN attributes	Mobile device default camera app	Smart device app	POS scanner status
EAN/UPC	Plain	No	No	Yes	Laser or imaging ready
GS1 DataBar Omnidirectional versions	GS1 element string	No	No	Yes	Laser or imaging ready
GS1 DataBar Expanded versions	GS1 element string	Yes	No	Yes	Laser or imaging ready
GS1 DataMatrix	GS1 element string	Yes	No	Yes	Imaging ready, updates may be required
Data Matrix	GS1 Digital Link URI	Yes	Some	Yes	Imaging software updates required
QR Code	GS1 Digital Link URI	Yes	Yes	Yes	Imaging software updates required

4.5.1 Using GS1 element string syntax

The GS1 element string syntax is widely used throughout the supply chain and supports the ability to provide important data where it is needed in healthcare, food, logistics units and a host of other locations. The majority of barcode creation and scanning solutions on the market already have the capability to encode and decode GS1 element strings used with linear barcodes such as the GS1 DataBar family and GS1-128, as well as the GS1 DataMatrix which is a retail POS compliant 2D barcode.

The GS1 element string syntax requires an understanding of GS1 Application Identifiers (AI) and their conformance requirements, as listed below. Once the required data is structured correctly as a GS1 element string, it is simpler to convert to a GS1 Digital Link URI for encoding into a 2D barcode. Please see Section [7.2.3](#) for information on the GS1 Barcode Syntax Resource and enabling capability for encoding solutions.

Key considerations for element string syntax:

- Selecting the correct GS1 AI to represent the encoded data, for example

- USE BY OR EXPIRY (17) vs BEST BEFORE or BEST BY (15)
- ORIGIN (422) vs COUNTRY - PROCESS (424)
- Data format
 - Data length, fixed or variable
 - Character sets e.g., numeric, alphanumeric, or restricted character set
 - Data components or segments e.g., check digits/characters, indicator digits or characters, ISO code lists, piece number and total count etc.
 - Whether a Function 1 symbol character (FNC1) is required as a separator character
 - Most AIs require a FNC1 to indicate the end of the AI data field and the start of the next AI. These are defined by GS1 standards as “non-predefined length” AIs, whereas the AIs that do not require FNC1 are defined as “predefined length” AIs. For information on “predefined length” AIs see Section 7.8.5 of [GS1 General Specifications](#).
- Data relationships
 - Mandatory pairs of AIs e.g., if serial number (21) is encoded, it must be encoded with GTIN to be meaningful
 - Invalid pairs of AIs e.g., if country of origin (422) is encoded, it cannot be encoded with country of full processing (426) as it can lead to ambiguous data
 - For details on data relationship requirements, see Section 4.13 of the [GS1 General Specifications](#).

4.5.2 Benefits of using GS1 element string syntax in 2D barcodes

The GS1 element string syntax in a GS1 DataMatrix barcode provides several benefits, contributing to efficient and standardized data encoding for identification purposes in the supply chain ecosystem.

- **Efficient use of space:** GS1 DataMatrix barcodes aim to encode a significant amount of information in a relatively small space. The structured GS1 element string syntax optimises data representation, allowing for efficient use of the barcode's capacity.
- **Enhanced data integrity:** GS1 element strings promote data integrity through the inclusion of check digits and other validation mechanisms ensuring that the encoded data is accurate and can be reliably interpreted.
- **Compliance with regulatory requirements:** Many industries, including healthcare and regulatory bodies, mandate the use of GS1 standards for product identification and traceability. GS1 element strings in GS1 DataMatrix barcodes help organisations comply with these requirements.
- **Traceability:** GS1 element strings enable the inclusion of unique identifiers, such as GTINs (Global Trade Item Numbers) or Serial Shipping Container Codes (SSCCs), ensuring each item is uniquely identified within the supply chain. Including Application Identifiers (AIs) for batch or lot numbers in the GS1 element string allows for traceability of products back to specific production batches, aiding in quality control and recall management. The use of AIs for serial numbers facilitates traceability at the individual item level. This is crucial for tracking and monitoring the movement of each unique product throughout its lifecycle.
- **Ease of set-up:** For those that do not require web connectivity, use of GS1 element string syntax can provide a smaller barcode than linear barcodes and more data without the additional set-up required to connect a GS1 Digital Link URI barcode to the web.
- **Existing GS1 element string syntax use:** GS1 element string syntax has been in use far longer than GS1 Digital Link URI. Barcodes like GS1 DataBar expanded and GS1-128 use the same data format as GS1 DataMatrix. As a result, it is more likely to be in systems than GS1 Digital Link URI. Scanners and backend systems are more likely to read and decipher the information in this syntax.
- **Focus on AI data structure only:** GS1 element string syntax may act as a transition phase between plain syntax to GS1 Digital Link URI syntax, as it only requires an understanding of

GS1 Application Identifiers (AI) and their conformance requirements. This means there is no need to understand key-qualifier versus parameters, or URI reserved characters etc.

4.5.3 Using GS1 Digital Link URI syntax

The GS1 Digital Link URI syntax can fulfil the exact same business processes that are fulfilled by a GS1 element string syntax today and well into the future (provided that the capability to recognise, use or convert a GS1 Digital Link URI has been enabled). However, a GS1 Digital Link URI has the added benefit of behaving like a Web URL to provide digital content about the data encoded in the 2D barcode. It can also provide different types of digital content to different users. See [Connecting barcodes to related information](#) for more information on this topic.

For example, consider a GS1 Digital Link URI with GTIN and batch/lot number, encoded in a QR Code or Data Matrix on a pack of steaks. When a consumer scans the 2D barcode with their mobile device's camera without any app, detailed traceability information about that specific batch of steaks can be provided, with web content possibly showing where the cow may have been born, raised, slaughtered and processed. Whereas for retail staff, the same 2D barcode can be scanned with a specialised app to retrieve traceability information about that specific batch of steaks, but this information is provided as structured master data which can be used for other business purposes, including those which may need to be automated or machine-readable.

Implementing or enabling capability to use a GS1 Digital Link URI requires knowledge of the syntax structure, subdomains and back-end coordination, when compared to GS1 element strings. See [Best practices for creating your QR Code powered by GS1](#) and the [GS1 Digital Link quick start guide](#) for more.



Important: It is important that a GS1 Digital Link URI is not used as the address of a web page. Rather, it is recommended to *redirect* to digital information about the identified product. There are two reasons for this. First, a GS1 Digital Link URI identifies the product itself, not the digital information about the product. Secondly, GTINs are allocated and managed according to the GS1 Allocation Rules whereas digital content, especially marketing-driven websites, are managed by brand marketing teams who will follow different procedures with different priorities. For more on this topic see [Best practices for creating your QR Code powered by GS1](#).

4.5.4 Benefits of using GS1 Digital Link URI syntax in 2D barcodes

Using GS1 Digital Link URI syntax creates 2D barcodes that are multifunctional, meaning they can connect consumers to the brand's website of choice, while also containing valuable information that simultaneously powers point-of-sale (POS) and many other business processes. Examples of advantages that contribute to a more transparent, engaging and efficient retail experience for businesses and consumers alike include:

- **Improved consumer engagement:** GS1 Digital Link URI syntax enables interactive experiences and enhanced consumer engagement. By scanning the barcode, consumers can be directed to websites, or other digital content related to the product or brand. This opens up opportunities for personalised marketing, loyalty programs, product tutorials, digital patient leaflets for pharmaceutical products, digital instructions for using medical devices, customer reviews and other interactive experiences that deepen the connection between consumers and brands.
- **Enhanced product information:** GS1 Digital Link URI syntax expands the capabilities of general use barcodes such as Data Matrix and QR Code, by enabling the inclusion of GS1 Identification with web links. Businesses can use this as access to additional product information, such as ingredient details, allergen information, sustainability data, product certifications and more. Consumers can access this information by scanning the barcode with a mobile device, enhancing transparency and enabling informed purchasing decisions.
- **Traceability and transparency:** GS1 Digital Link URI syntax can be used to embed additional data, such as batch/lot number or serial number, which enables consumers and businesses to access online traceability information, associated with the GTIN and batch/lot or serial number. This creates opportunities for businesses to provide real-time supply chain visibility to

consumers. For instance, consumers can trace the origin of a product, view production or harvest dates, learn about quality control measures and understand the environmental impact of the product's lifecycle. This transparency can help build consumer trust and support sustainable and ethical purchasing decisions.

- **Simplified mobile commerce:** GS1 Digital Link URI syntax enables seamless integration between physical products and online commerce platforms. By scanning the barcode, consumers can access e-commerce websites, product catalogues, or online marketplaces directly from their mobile devices. This simplifies the purchasing process, enabling consumers to explore additional product variations, check prices, read reviews and make convenient online purchases.
- **Flexibility and future-proofing:** GS1 Digital Link URI syntax is designed to be flexible and adaptable to evolving technology trends. It supports various barcode formats, including QR Code and Data Matrix. This flexibility helps ensure compatibility with different scanning devices and software applications, allowing businesses to future-proof their barcode implementation.

4.6 Optimising the 2D barcode size and data

Optimising the size and data encoded in a GS1 DataMatrix, Data Matrix or QR Code can improve scanning performance as 2D barcodes with an overall smaller size are generally, faster to scan and take up less space on-pack. It is expected that all barcodes are produced in compliance with the *GS1 General Specifications* and relevant ISO/IEC standards.

- ✓ **Important:** The size referenced is the overall size of the barcode and not the size of the barcode's X-dimension. X-dimension that goes below the allowed sizes in the GS1 General Specifications Symbol Specification Tables are more difficult to scan than larger X-dimension sizes.

When the 2D barcode is compact, it reduces the time required for a scanning device to capture and interpret the information as the 2D barcode is completely in view of the scanner faster. When printing GS1 DataMatrix, Data Matrix or QR Codes on small trade items, or on curved surfaces the size becomes a critical factor. Smaller 2D barcodes are more effective for printing on garment tags, labels, or packaging, and they are also more suitable for display on mobile screens. In addition, small efficiently encoded 2D barcodes can reduce the amount of data that needs to be transferred over a network and ease the printing of dynamic data (e.g., serial numbers) based barcodes. There are several other advantages to having a 2D barcode size that is optimised, such as:

- **Transition period:** During the 2D migration transition period both linear and 2D barcodes will need to coexist, so optimising the 2D barcode size helps ensure brand marketing and packaging designers still have sufficient space for their purposes.
- **Readability and reliability:** An optimised 2D barcode is more likely to be readable under various conditions. This includes scenarios with poor lighting, low-resolution cameras, or when the code is partially obscured or if the surface is not flat. Optimising size and data encoding helps improve the reliability of scanning.
- **Mobile app performance:** Mobile devices, especially older models or those with limited processing power, may struggle with decoding large or complex 2D barcodes. Optimising size and data encoding can improve performance on a wide range of devices.
- **Aesthetic considerations:** In applications where 2D barcodes are part of a design, such as marketing materials or product packaging, a smaller, well-optimised code can be more aesthetically pleasing and less obtrusive.

In summary, optimising the size and data encoded in 2D barcodes is crucial for improving scanning performance, ensuring readability, enhancing user experience, and addressing practical considerations related to printing, display and data capacity. Optimising the encoding of a 2D barcode involves adjusting various parameters to ensure that the 2D barcode is efficient, readable and reliable. Sections in [4.6.1](#) below provides an overview of the various parameters that can affect the size of 2D barcodes. Note that the size of the 2D barcode will be determined by the specific symbology selected along with these parameters.

For more information, see the following references:

- **Best practices for creating your QR Code powered by GS1:** https://ref.gs1.org/docs/2023/QR-Code_powered-by-GS1-best-practices
- **Connecting barcodes to related information:** <https://ref.gs1.org/docs/2024/connecting-barcodes-to-related-information>
- **GS1 Digital Link quick start guide:** <https://ref.gs1.org/docs/2024/digital-link-quick-start-guide>
- **GS1 DataMatrix Guideline:** https://www.gs1.org/docs/barcodes/GS1_DataMatrix_Guideline.pdf

4.6.1 Data and format considerations

The format of data encoded in a 2D barcode, as well as the type of data included, can also have an impact on the physical size of the barcode produced. It is important to be mindful of the following considerations.

- **Variable length data**
 - When using variable length GS1 Application Identifiers (AIs), the available capacity does not necessarily need to be filled to its maximum, as more data can result in a larger barcode.
 - For example, the amount payable for a variable measure trade item (392n) allows up to 15 characters, however a 6-character amount with the decimal point indicator can be sufficient for most use cases.
 - Another example is the serial number (21), which allows up to 20 characters, however a 10-character serial number can be sufficient as it must be used with a GTIN to uniquely identify a specific trade item instance.
- **Note:**  The same 10-character serial number can be used repeatedly with different GTINs, as it is the combination of the GTIN and serial number that provides unique identification of the trade item.
- **Characters**
 - Some AIs allow alphanumeric characters that include digits, lowercase and uppercase alpha characters, and special characters such as "-", "/", "#" etc.
 - Different types of characters require different amounts of data capacity when encoded, and switching between character types can also require more data capacity when switching between encoding modes.
 - The choice of characters within a data string can impact the size of the barcode produced:
 - Digits use the least amount of data capacity when compared to alpha or special characters.
 - Uppercase characters use less data capacity when compared to lowercase or special characters.
 - Changing between character types requires more data capacity than when using a single character type.
 - Encoded data:
`https://example.com/01/09526064055028/22/TEST/10/ABC123/21/435DER?17=250521` **versus**
`https://example.com/01/09526064055028/22/test/10/abc123/21/435der?17=250521`

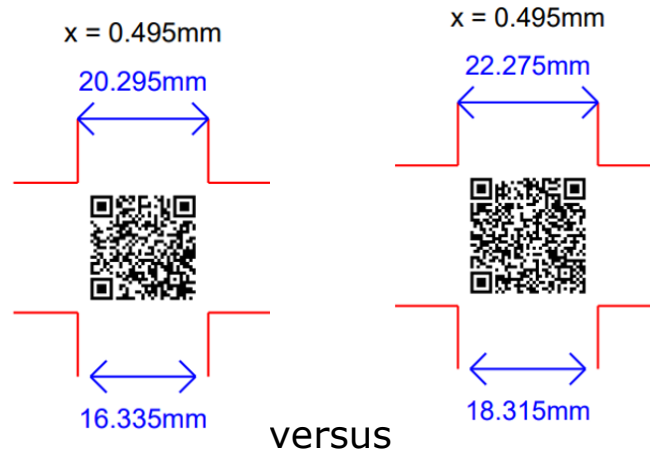

Figure 4-14 QR Code (error correction M) uppercase versus lower case encoding

- For technical details on the use of GS1 Digital Link URI structures, including percent encodings in QR Codes, see Section [7.2.2](#).
- **Sequence of predefined versus non-predefined length data for GS1 element string only**
 - The sequence of predefined and non-predefined length AIs can have some impact on the size of a barcode, although it's worth noting that the impact is minimal, when compared to the previous points.
 - When encoding a GS1 element string, all "non-predefined length" AIs except for the last data element in the string, require the Function 1 symbol character (FNC1) to be used as a separator character.
 - Switching between encoding modes to encode a FNC1 uses additional data capacity, therefore it is recommended to encode the predefined length AIs before any non-predefined length AIs where possible.
 - More information can be found in the [GS1 General Specifications](#), Section 7.8 Processing of data from a GS1 symbology using GS1 Application Identifiers.
- **Minimum data set for encoding**
 - The amount of data encoded in a 2D barcode can directly impact the physical size of the 2D barcode produced, and adding more data into the barcode can increase complexity to create it.
 - Not all data needs to go into a barcode to be useful. Only data that is essential to be automatically captured and acted upon goes into a barcode. Other data can be associated or linked to through other means.
 - For example, a retailer might require Country of Origin on all cosmetic trade items to provide online traceability information to consumers, as well as for import and export requirements.
 - Country of Origin for the trade item can be encoded with (422) along with GTIN (01). It will also likely be associated with the trade item's batch/lot number (10), as each batch/lot can be produced in different locations.
 - In this case, Country of Origin is not needed at POS, but is needed for general distribution and for digital content directed at consumers. So, the 2D barcode applied to the trade item only requires the GTIN (01) and batch/lot (10) to be encoded, since the Country of Origin data can be associated with the GTIN and batch/lot number, as master data for B2B requirements, and as linked data for B2C requirements.

4.6.2 Choose the right encoding strategy

GS1 DataMatrix, Data Matrix and QR Code support different encoding modes (e.g., numeric, alphanumeric, binary, and Kanji). The encoded barcode data is a sequence of message segments, each encoding a section of the data in a certain mode.

Careful selection of the sequence of modes that best suits the type of data in different sections of the message can minimise the size. For example:

- If the data primarily consists of consecutive run of numbers, using the numeric encoding mode for that section can result in a more compact barcode.
- If the data includes a combination of numbers and letters, the alphanumeric encoding mode might be more efficient than binary mode within that section.

In the encoded barcode message, non-data characters, or segment headers, facilitate transitions between different encoding modes. However, these mode shifts come with an encoding length cost. Therefore, frequently changing modes to represent short runs of specific data types may outweigh any potential benefits. Different encoding schemes can be employed to represent the same barcode message, each with varying levels of efficiency.

Ideally the barcode encoder (image generator) will determine the optimal sequence of mode changes that minimises the overall length of encoded messages for the given data. This strategic approach to message encoding can often lead to a reduction in the size of the barcode image. When generating a GS1 DataMatrix, Data Matrix or QR Code, the choice of encoding mode is often handled automatically by the encoding software based on the content being encoded. Most barcode generators will follow the informative optimisation procedure described by the relevant symbology standard. However, some barcode generators do not use optimisation techniques and will instead resort to a single mode for the entire message.

Users typically do not need to manually specify the encoding mode, but it can be useful to understand how the different modes work if you want to optimise QR Code generation for specific types of data. Users are advised to do their own testing with a range of available encoder toolkits to make their own assessment about which provide the most efficient encoding.

The many commercial and open-source barcode encoding software solutions include automatic encoding mode sections leading to a mixed mode 2D barcode. These mixed mode 2D barcodes are supported by scanner solutions that conform to the ISO standards for GS1 DataMatrix and Data Matrix: ISO/IEC 16022 *Information technology – Automatic identification and data capture techniques – Data Matrix barcode symbology specification* and QR Code: ISO/IEC 18004 *Information technology – Automatic identification and data capture techniques – QR Code barcode symbology specification*.

See Annex 8.3 for the details of the encoding modes used in GS1 DataMatrix, Data Matrix and QR Codes.

4.6.3 Adjusting error correction level

Choose the appropriate level based on the required error correction for the specific use case. Higher error correction levels add redundancy but increase the size of the barcode, therefore the impacts on the printing, scanning and packaging need to be considered. GS1 DataMatrix, Data Matrix and QR Code use Reed Solomon error correction (ECC).

- Data Matrix ECC is determined by the code size and the remaining storage capacity, The ECC is automatically included and is typically 30% of the barcode.

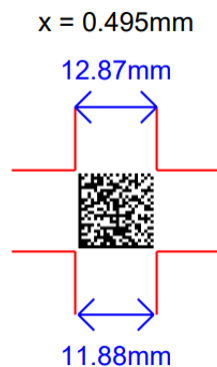
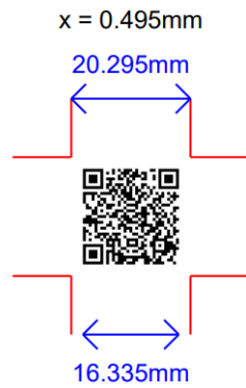

Figure 4-15 Example Encoded data:
(01)09526064055028(17)250521(22)test(10)abc123(21)435der

- QR Code ECC can be selected manually (i.e., L, M, Q and H). A higher error correction level can mean less storage capacity if there is 2D barcode size constraint.

Low: 7%



Medium: 15%

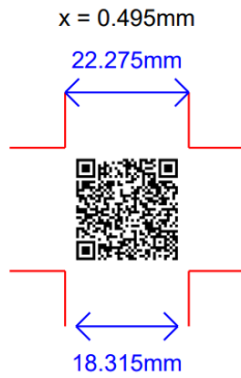

Quartile: 25%

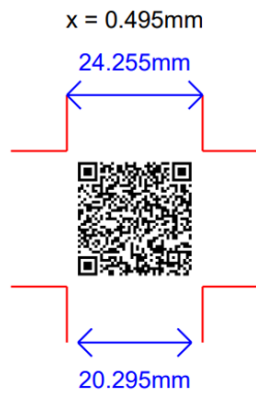

High: 30%

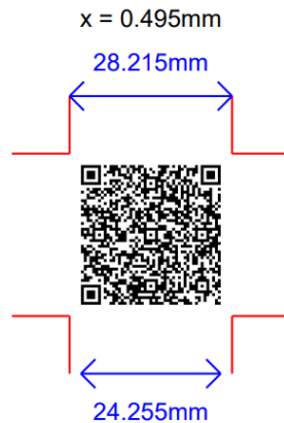

Figure 4-16 QR Code with ECC for example encoded data:
<https://example.com/01/09526064055028/22/test/10/abc123/21/435der?17=250521>

In summary, the ECC in GS1 DataMatrix, Data Matrix and QR Code is a critical feature that enhances the reliability and robustness of these 2D barcodes over linear barcodes. Users can tailor the QR Code error correction level to suit their specific needs, ensuring optimal performance in various applications.

4.6.4 Adjusting X-dimension and Quiet Zone

In 2D barcodes, the X-dimension refers to the size of the individual modules that make up the barcode. In 2D barcodes, the modules are most commonly squares or dots. Smaller modules can result in a more compact barcode but making them too small can prevent reliable scanning. The GS1 Application Standard for Retail POS sets the ranges for acceptable module X-dimension size to enable reliable decoding of GS1 DataMatrix, Data Matrix and QR Codes in the retail environment. See GS1 General Specifications:

- **Symbol specification table 1 addendum 2 for 2D barcodes** for trade items scanned in general retail POS and not in general distribution.
- **Symbol specification table 3 addendum 1 for 2D barcodes** for trade items scanned at general retail POS and in general distribution.

As noted in the *GS1 General Specifications* the X-dimensions for 2D barcodes are 1.5 times the equivalent X-dimensions allowed for the linear barcode.

The Quiet Zone is the empty margin around all four sides of a 2D barcode. An adequate Quiet Zone is necessary for the 2D barcodes quick identification on packaging, proper scanning and to avoid interference that will prevent the reader from identifying the barcode. For GS1 DataMatrix and Data Matrix, the Quiet Zone is equal to the X-dimension on all four sides. For QR Code, the Quiet Zone is 4 times the X-dimension on all four sides.

For example, if an X-dimension of 0.495 mm was used, the minimum Quiet Zone surrounding a GS1 DataMatrix or Data Matrix would be 0.495 mm. For QR Code, it would be four times the X-dimension, 1.980 mm.

See the GS1 General Specifications symbol specification table 1 - Trade items scanned in general retail POS and not general distribution.

To assist with visualising the 2D barcode size GS1 has created a [GS1 Module Count tool](#).

4.6.5 Use of images, colour and other modifications in 2D barcodes

Some brand owners wish to modify the barcodes on products to incorporate images, colours, shapes or other elements they believe are more appealing to those looking at the product. This is especially prevalent with QR Codes used for marketing and consumer engagement applications. Ideal 2D barcodes have highly contrasting light and dark modules, such as black and white, feature a perfect

grid using even, square modules, are in no way shortened or cut off and do not have their error corrections compromised. If proceeding with the use of 2D barcodes with modifications like what has been mentioned, it is critical to have each unique barcode verified in accordance with ISO/IEC 15415 and the relevant symbology standard to determine the barcode's quality grade and compliance with the GS1 General Specifications requirements.

The following areas are most frequently impacted by modifications that lead to issues with barcode performance. For details on the quality assessment see [7.2.1](#).

- **Finder pattern:** Each barcode has a specific pattern that barcode readers look for to determine that what is in its field of view is a barcode and what type of barcode it happens to be. When these patterns are distorted or modified, it will become difficult for barcode scanner solutions to identify and decode the barcode.
 - GS1 DataMatrix and Data Matrix uses an **"L" pattern**
 - **Alignment + clocking pattern**



Figure 4-17 Example of the Data Matrix finder pattern

- QR Code uses **three square structures** in its corners **Alignment + clocking pattern**



Figure 4-18 Example of the QR Code finder pattern

- **Quiet Zone:** The Quiet Zone is the empty space that surrounds all four sides of a 2D barcode. This space helps barcode readers to locate the barcode's finder pattern and begin to process the information. Removing the quiet zone or putting graphics, colours or other 'noise' in the Quiet Zone space can harm barcode performance.
 - GS1 DataMatrix and Data Matrix uses **one X-dimension** (size of one module or square) for the **Quiet Zone**



Figure 4-19 Example of the Data Matrix Quiet Zone

- QR Code uses **four X-dimensions** (size of one module or square) for the **Quiet Zone**



Figure 4-20 QR Code Quiet Zone example

- **Contrast:** Use of colours with poor contrast and having more than two colours can be problematic for barcode performance as barcode readers may have difficulty determining which modules are light and which are dark. This can cause a barcode to fail. Due to the use of red light in barcode scanning and verification, using colour red for the dark modules can be highly problematic and is to be avoided.



Figure 4-21 Example of contrast

- **Uniformity:** GS1 DataMatrix, Data Matrix and QR Code are designed to be in an even grid pattern where every module is a filled in square. When the grid pattern is warped, or the modules shapes are changed (e.g., star, swirl, heart) the barcode becomes more difficult to be read correctly as the standardised, expected patterns are disrupted.



Figure 4-22 Example of grid uniformity

- **Error correction:** When images are inserted into 2D barcodes, that image is using the error correction space that would otherwise be redundantly encoding the data contained in the barcode to support improved readability. As the space used for images in the barcode increases, the likelihood that barcode will perform as intended decreases.
- ✓ **Note:** Logos and other images are not an integrated part of the ISO/IEC 16022 and ISO/IEC 18004 technical specifications GS1 normatively references respectively for the GS1 DataMatrix, Data Matrix or QR Code encoding design. Therefore, logos and other images are technically considered as damage, since they generally sit on top of the data, blocking information. The only reason they still work is the result of Reed Solomon error correction that allows the data to be rebuilt. If the logo is too large or positioned in a way to compromise the locating feature or error correction modules, this will cause a decode failure.



Figure 4-23 Example of ECC level indicator

- Colour:** Barcode scanners and verification systems are often illuminating the barcode and substrate with red light, 660nm, therefore red, orange and yellow 2D barcodes will be difficult to decode. Human factors like colour blindness should also be considered and, in particular red-green colours are good to avoid. The best colour combination to support consistent reading is black and white.



Figure 4-24 Examples of colour versus black scanning

- Important:** Consumer mobile devices and the barcode hardware used throughout the supply chain use different technologies and can have widely varying form factors. A barcode that works well with a consumer device may not read well at retail point-of-sale.

4.7 Printing, reading and processing barcodes

Printing, reading and processing the data from 2D barcodes will be discussed through the lens of brands, retailers and solution providers throughout this document. Three topics warrant further investigation: the distinction between static and dynamic printing, the security consideration of scanning 2D barcodes and the utilisation of 2D barcodes in conjunction with GS1 Digital Link URI and resolvers.

4.7.1 Static vs. dynamic data

The terms static and dynamic are used widely across different applications. Generally, the term “static” is used to describe things that are consistent and remain the same, while “dynamic” represents items that are able and expected to change. The GTIN and some of the data typically associated with it are static, meaning they are consistent data and are the same across all individual units of a specific trade item. Additional static data such as the ingredient list and regulatory information can be printed on the package or stored in master data and shared via systems like the GS1 Global Data Synchronisation Network™ (GDSN®).

The use of additional data on packaging increases the use of dynamic data (e.g., batch/lot number, expiration date, serial number), which can vary across instances of the trade item. For example, a lot number on a tube of toothpaste can be associated to the production date, manufacturing location and even a specific production line. A serial number on a seafood item could be associated with information about the waterway and fishing method. This data can be used for B2B purposes,

facilitating traceability or targeted product recalls. With GS1 Digital Link, a web link (URL) with dynamic data can be encoded in the data carrier that links to a webpage specific to the lot or serial number. EAN/UPC barcodes can only accommodate static data while 2D barcode like GS1 DataMatrix or QR Codes can use dynamic data.

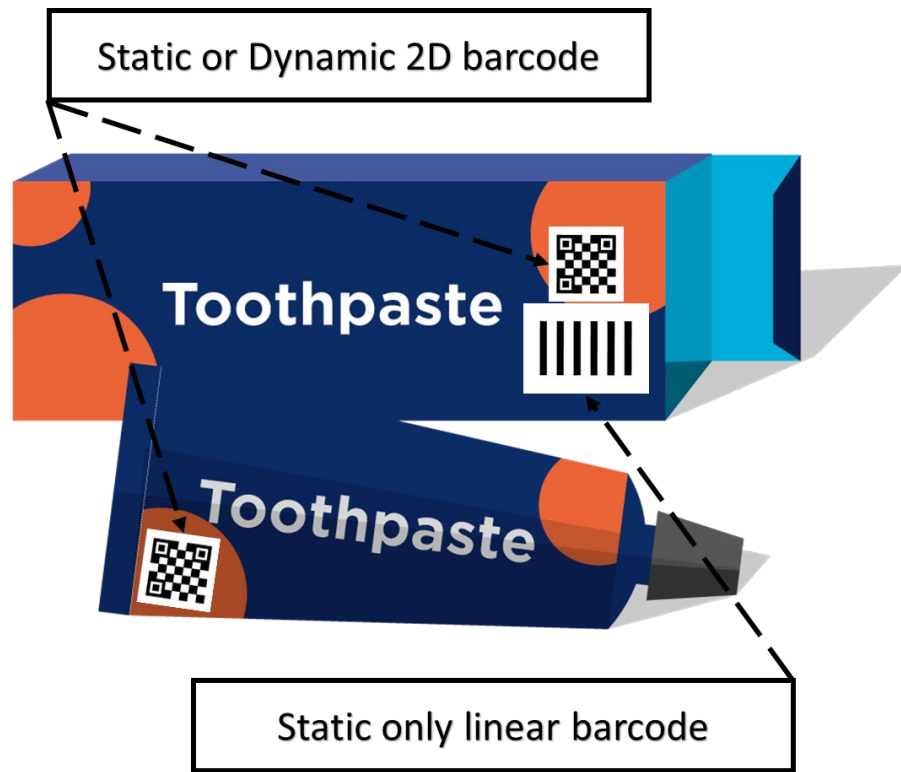

Figure 4-25 Static and dynamic barcodes

Dynamic data needs to be printed, stored, shared and processed differently than static data. For use cases, such as with food items, the static GTIN in a barcode and nutritional information may arrive at the manufacturing plant pre-printed by packaging suppliers. Dynamic data such as expiration dates and batch/lot codes is usually printed on demand at the plant or production line. As more dynamic attribute data is encoded into data carriers on packaging, brand owners and manufacturers will need to adapt their processes.

Table 4-5 Static versus dynamic data

	Static	Dynamic
Barcode data	Data that is encoded into the barcode on all instances of a trade item: <ul style="list-style-type: none"> ■ GTIN 	Data that is encoded into the barcode can vary across instances of a trade item: <ul style="list-style-type: none"> ■ Batch/lot number ■ Expiration date ■ Best before data ■ Serial number ■ Weight

	Static	Dynamic
Packaging / Printing	<p>Consistent across the GTIN and is often pre-printed.</p> <ul style="list-style-type: none"> ■ Nutrition facts panel ■ EAN-13, UPC-A ■ 2D barcode with only GTIN 	<p>Printing applied at the time of manufacturing or at various different stages that can vary across instances of a trade item:</p> <ul style="list-style-type: none"> ■ Best before date ■ Batch/lot number ■ 2D barcode encoding GTIN and additional data
Web links	<p>The link is the same and provides the same experience across all instances of the trade item.</p>	<p>The link can be directed to different experiences based on the instance of the trade item and other factors.</p> <ul style="list-style-type: none"> ■ Traceability information varies based on batch/lot number and/or serial number. ■ Users in different markets see different content relevant to them.

4.7.2 2D barcodes with static data

The first example in Figure 4-26 is a bottle with an EAN/UPC barcode at the bottom and a marketing consumer engagement QR Code with GS1 Digital Link URI syntax at the top of the label. There is no HRI associated with the QR Code because the brand owner intends the QR Code only for consumer engagement, not the point-of-sale (POS). The same GTIN is used in the EAN/UPC and 2D barcode with no additional data. This example is what we would call static data, wherein the label was produced ahead of time and then is applied at the production line. The data in the barcodes remains static across all packages. Without changes to the barcode or product packaging, the experience linked to through the QR Code with GS1 Digital Link URI can be updated by the brand owner.



Figure 4-26 Example of static data printing

4.7.3 2D barcodes with dynamic data

Figure 4-27 is dynamic data in a fresh food use case, where there is a need to track a product with an expiration date and batch/lot number to help with food safety. In this example with a GS1 DataMatrix, the expiration date and a lot number are being printed and applied to the packaging at the moment of production. This is also known as on demand or dynamic data printing.



Figure 4-27 Example of fresh food dynamic data 2D barcode printing

As another dynamic data example, a serial number is included as the brand owner wants to uniquely identify every individual instance of a product. This approach works well for applications such as apparel where there is a GTIN and serial number in a RFID tag or 2D barcode. Implementation can occur either during the apparel item's production process or post-production, such as at a service bureau facility, see Figure 4-28.

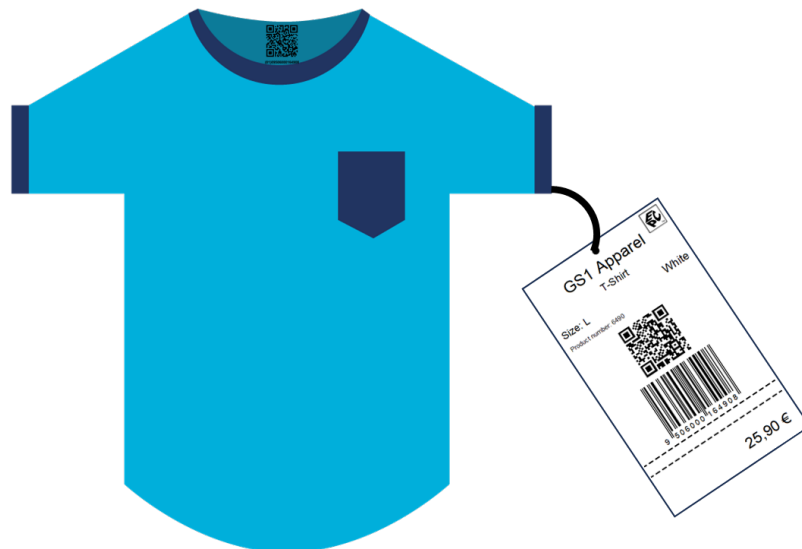

Figure 4-28 Example of apparel dynamic data 2D barcode printing

In the final example shown in Figure 4-29, the label is a preprinted QR Code with GS1 Digital Link URI with GTIN and serial number in it. This is an interesting solution option because this is not dynamic printing at the production line. This dynamic printing occurred before the production processes. When the label with the serial number is applied and goes along the production line, the camera that is inspecting the QR Code reads the barcode and stores the serial number in a database. Until the scanner reads the QR Code with the serial number and sends the data to the database, the product is not visible to the production environment.



Figure 4-29 Example of pre-printed dynamic data

4.7.4 2D barcode security

Can 2D barcodes be used by bad actors to “hack” or exploit the consumer scanning the QR Code? Since QR Codes can carry web links then hackers can exploit their capability just like they do in emails. This practice is known as Quishing, an amalgamation of QR Codes with Phishing. Phishing is where a bad actor attempts to get personal information often through email. These Quishing QR Codes would likely be in an email or on a public wall, not encoded in a brands’ or retailers’ QR Codes powered by GS1 Digital Link URI.

QR Codes are neither inherently safe nor unsafe. They are neither secure nor insecure. It is the software used to scan them and the behaviour of the user that will determine whether scanning a QR Code leads to ‘good’ information or ‘bad’.

For the consumer or anyone that uses a smart device to scan a bad actor’s QR Code the same warnings and protocols that we use for email phishing still apply. It is often difficult to identify where the URL will link us to, but the brand or retailer can help by selecting a domain name that will resonate with and give confidence to the user. Today our digital accounts often have two factor identification, so safety nets do exist if we choose to enable them.

For some applications, the 2D barcode will contain information in addition to the product identifier (GTIN), such as batch number, serial number or expiry date. This additional information provides even more granular identification of the product to which the 2D barcode is applied. Combined with traceability data about the product’s movements, or data sharing via a common national or regional database, the 2D barcodes, similar to other GS1 barcodes that contain this granular information can be used to help prevent product counterfeiting. This is seen today in applications for pharmaceuticals, amongst other industries. Many healthcare product manufacturers prefer to

randomise the serial numbers in the GS1 DataMatrix to make it more difficult for counterfeiters to guess the sequence in an attempt to make fake product seem more legitimate.

As with any implementation of web information that can be accessed by consumers, care must be taken to understand security risks and threats. While QR Codes by themselves don't pose risk, companies need to consider the same security and privacy policies they have for their brand/corporate website for their product information pages that may be linked from a QR Code. For additional information, see "Introduction to QR Codes" by the U.S. Government (<https://digital.gov/resources/introduction-to-qr-codes/>) and "Security considerations for QR Codes" by the Canadian government centre for cyber security (<https://www.cyber.gc.ca/en/guidance/security-considerations-qr-codes-itsap00141>) and FBI QR Code Advisory (<https://www.ic3.gov/Media/Y2022/PSA220118>)

4.7.5 Resolver

The term 'resolver' is used for any service that connects an identifier to an information source. A GS1-conformant resolver connects a GS1 identifier to one or more sources of information about the identified entity. For example, it can connect a product's GTIN to a web page about the product, instructions and ideas for how to use the product, sustainability information and more. Likewise, it can connect an air conditioning unit to a detailed product specification, its installation and service history. In healthcare applications, it could be pharmaceutical information for patients, distinct from that for clinicians, all in the correct language and according to the local regulations, as well as electronic Product Information Leaflets (ePIL) Summaries of product characteristic (SmPC) and electronic Instruction for Use (eIFU) for healthcare products.

By following the standard, GS1-conformant resolvers can operate as a network with no single point of failure. Information about a product, asset or location remains within the data owner's own system with the resolver network acting as a discovery service.

GS1 Member Organisations, solution providers and brand owners are all encouraged to operate resolvers according to their own business practices, but the input is always a GS1 Digital Link URI. Applications can query any resolver in the network with a common set of commands and expect a common set of responses. In healthcare applications, refer to local or jurisdictional regulatory validation systems requirements and good practice quality guidelines, sometimes known as GxP, that further govern the type of content to which the scan is directed,

To learn more about resolvers please visit the [GS1-Conformant Resolver Standard](#).

5 Implementation guidance for brands and manufacturers

Whether exploring 2D barcodes for the first time or modifying an existing implementation, those producing products have a great deal to consider. Section 5 provides guidance on determining where to start, who to involve, what type of data to include in which barcode, where to put the barcode and additional details to support a successful 2D barcode implementation at retail point-of-sale (POS).

This section is intended to be used by brand owners, Global Trade Item Number (GTIN) allocators, manufacturers and retailers with private label or fresh products labelled in-store. Throughout this guideline, these parties are referred to as brands.

 **Note:** The brand manufacturer/owner-specific guidance in Section 5 expands on the general information found in Section 4. Retailers seeking information on enabling 2D barcode capabilities at POS and in-store barcode production use cases will refer to Section 6.

5.1 Brand manufacturer roles in 2D implementation

When a brand manufacturer is considering the use of GS1 2D barcodes on a trade item, different areas of the organisation will need to be involved in guiding the strategic and tactical efforts needed to introduce these barcodes or transition from existing barcodes. The table below outlines some key roles that may need to be involved, depending on numerous factors including the specific implementation, the size of the organisation and the speed with which 2D will be introduced. The

table is a guide to consider and not comprehensive. Every organisation will need to tailor their project(s) to fit their specific requirements or constraints.

Table 5-1 Brand/manufacturer roles and responsibilities relevant to 2D implementation

Role type	Role description / responsibilities	2D implementation responsibility	2D implementation dependencies
Brand owner	<ul style="list-style-type: none"> Organisation that owns the specifications of the product 	<ul style="list-style-type: none"> Responsible for coordinating the use of 2D barcodes 	<ul style="list-style-type: none"> Has engaged internal teams working throughout the organisation as well as external partners, as needed, during the full 2D barcode process
Business insights /data analytics team	<ul style="list-style-type: none"> Focused on internal business trends and addressing business needs/improvements (more focussed on deeper detail – day to day operations) Provides the user interface/solutions for internal functions, e.g., dashboard 	<ul style="list-style-type: none"> Shape pilot and implementation goals based on insights Establish metrics to track and assess Incorporate insights into business processes 	<ul style="list-style-type: none"> Important to include throughout processes to help create, monitor and adapt plans based on insights
Category Managers/Buyers/Purchasers/ Commercial	<ul style="list-style-type: none"> Contract management Liaison between technical teams of trading partners Manage vendors and suppliers Responsible for selection of trading partner 	<ul style="list-style-type: none"> Communicates requirements for barcode data and quality Manage commercial impacts (e.g., change management) 	<ul style="list-style-type: none"> Initiates the discussions about transitioning to 2D barcodes with suppliers Discuss impacts, benefits and timelines, helping stakeholders to mitigate commercial impacts Works with suppliers to transition to 2D barcodes
Customer insights	<ul style="list-style-type: none"> Compilation and assessment of store-specific feedback from customers Loyalty/membership features Customer segmentation/trends Social media analysis 	<ul style="list-style-type: none"> Provide opportunity for customer to provide feedback on 2D barcodes when piloting 	<ul style="list-style-type: none"> Include in planning and key milestone check points
Industry Solutions Business Solutions (e.g., Traceability, Sustainability, Circularity)	<ul style="list-style-type: none"> Oversee planning and execution of business programme or project 	<ul style="list-style-type: none"> Ensures implementation of 2D barcodes based on initiatives given under role type 	<ul style="list-style-type: none"> Analyse if the 2D barcode solution is achieving the necessary goals. For example, if they have the right data for traceability, if the 2D barcodes helps achieve sustainability objectives Ensuring the correct sustainable disposal of obsolete equipment

Role type	Role description / responsibilities	2D implementation responsibility	2D implementation dependencies
IT – ERP, Data governance, POS, WMS	<ul style="list-style-type: none"> ■ Oversee technology infrastructure, managing data systems, and ensuring cybersecurity ■ Ensure interoperability amongst the different systems ■ Ensure data is delivered to printing/scanning systems and POS systems in the right way 	<ul style="list-style-type: none"> ■ Connection with input/output hardware ■ Supply the right data ■ Collect and correctly process the additional data 	<ul style="list-style-type: none"> ■ Enable additional data and data structures in a manufacturer or retail environment ■ Critical for piloting to ensure data connectivity between IT systems
Leadership CEO/Directors/Senior Leadership/Store Owners	<ul style="list-style-type: none"> ■ Oversee strategy, operations, and finances 	<ul style="list-style-type: none"> ■ Critical sponsor of transformation project(s), need to support/understand value of 2D transition 	<ul style="list-style-type: none"> ■ Can be the starting point to identify 2D opportunities ■ Needs to support and understand value of 2D transition - Benefits and ROI must be clearly established for buy-in/to confirm support
Legal	<ul style="list-style-type: none"> ■ Will need to be aware of transition and consulted wherever there may be legal issues 	<ul style="list-style-type: none"> ■ Awareness ■ Advisory role as needed ■ Consultation on regulatory matters 	<ul style="list-style-type: none"> ■ Consulted throughout the implementation process
Marketing	<ul style="list-style-type: none"> ■ Manage brand and external communications including public relations (PR) packaging artwork/design 	<ul style="list-style-type: none"> ■ Awareness ■ May be required for PR management and customer queries during transition period 	<ul style="list-style-type: none"> ■ PR management after migration completed (e.g., food safety guarantee)
Master data	<ul style="list-style-type: none"> ■ Responsible for creating products master data and setting up in the system 	<ul style="list-style-type: none"> ■ Communicates the right data elements are established in the required systems for encoding into 2D ■ Communicates the right AIs are established in the required systems for encoding into 2D 	<ul style="list-style-type: none"> ■ Ensures the right GTIN has the right attributes attached to it
Omnichannel Distribution Managers	<ul style="list-style-type: none"> ■ Oversee the distribution and fulfilment operations across multiple channels ■ Ensure products are delivered to customers in a timely, cost-effective, and seamless manner 	<ul style="list-style-type: none"> ■ Assessing the different distribution channels specific needs for 2D barcodes 	<ul style="list-style-type: none"> ■ Follow up with and ensure business partners timely readiness

Role type	Role description / responsibilities	2D implementation responsibility	2D implementation dependencies
Product development	<ul style="list-style-type: none"> ■ Packaging and artwork development 	<ul style="list-style-type: none"> ■ Creates new packaging artwork to accommodate 2D Barcode, HRI and non-HRI ■ Removal of EAN/UPC for retailer brand articles, when appropriate and agreed by impacted stakeholders 	<ul style="list-style-type: none"> ■ Plan and develop new packaging artwork for the supplier/manufacturer to transition to 2D barcodes
Production managers Line managers	<ul style="list-style-type: none"> ■ Overall efficiency of the production line to meet production goals 	<ul style="list-style-type: none"> ■ Ensure how to add additional process (for example, inline dynamic data printing) without causing too much disruption to the production line 	<ul style="list-style-type: none"> ■ Scheduling for updating of process ■ Ensure availability of associates to be trained for piloting
Quality assurance/control	<ul style="list-style-type: none"> ■ Ensures quality of products provided by the supplier, including packaging and barcode quality issues 	<ul style="list-style-type: none"> ■ Identifies quality issues and communicates with commercial and manufacturers to address ■ Check barcode quality (can be random), generally done at various points pre-production. Once completed, supplier is approved for production. ■ Identifies and records data quality e.g., instances of wrong data (where other processes are impacted) 	<ul style="list-style-type: none"> ■ Test sample products content, packaging and 2D barcodes before manufactures starts full production ■ Data types/format etc needs to be defined (by project/ master data/ transformation teams)
Supply Chain Managers	<ul style="list-style-type: none"> ■ Work with procurement teams and buyers to source the right products ■ Control manufacturing and delivery processes 	<ul style="list-style-type: none"> ■ Ensure all actors in the supply chain are aware of migration ■ 2D barcodes can be scanned at all points necessary in the supply chain 	<ul style="list-style-type: none"> ■ Liaise with partners to ensure that implementation needs are met in time to support the processes
Webmaster	<ul style="list-style-type: none"> ■ Ensure website services effectiveness 	<ul style="list-style-type: none"> ■ Implementation and alignment for visitors' and users' positive experience 	<ul style="list-style-type: none"> ■ Ensure the webpages are up-to-date ■ Revise/Redirect websites pages, links and information as necessary

5.2 When to start transitioning to 2D barcodes

Each company will have their own, unique business needs that will determine which product or products will first transition to using a 2D barcode and what that barcode will contain. For guidance on determining what to include in the barcode, see Section [5.4](#).

Important: Linear barcodes, such as EAN/UPC and the GS1 DataBar retail POS family, will still be available for use. GS1 standards will continue to allow the use of linear barcodes. Exceptions may occur if regulatory or legal requirements mandate only the use of a 2D barcode.

5.2.1 Common reasons to begin a transition to 2D barcodes

The following are the most common reasons why the transition to 2D barcodes begins.

- **Consumer engagement opportunity:** Whether it is sharing recipe ideas, promotions, handling instructions, certifications connecting consumers to social media or all the above, brand owners need improved ways of connecting consumers to experiences through a product and its packaging. Fulfilling this need to create consumer engagement experiences is a key reason many companies transition to 2D barcodes.
- **Package design constraints:** Limited space on products and packaging for design elements, consumer engagement, declarations or other information lead many companies to explore the use of 2D barcodes to consolidate multiple barcodes to free up space, extend packaging online, and provide transparency to consumers and supply chain stakeholders.
- **Regulatory requirements:** For some product types, regulatory requirements may be in place that only 2D barcodes can support. Many times, these regulatory requirements overlap with other business drivers for transitioning to 2D barcodes. For information on using 2D barcodes to support regulatory requirements, contact your local [GS1 Member Organisation](#).
- **High-risk product categories:** Certain product types have a higher need for additional data and/or consumer transparency, separate from regulatory compliance requirements. Many brand owners will prioritise their 2D barcode migration based on which products can most benefit from more data encoded in the barcode or linked to an online experience. Products more likely to be subject to recalls, counterfeiting, having expired product on-shelf are some examples of what brand owners may begin with.
- **Supply chain or retail need:** 2D barcodes are capable of encoding data that can support a wide variety of information to support supply chain and retail needs that also work towards keeping consumers safe and satisfied. Product types that most benefit from data such as batch/lot numbers, dates, country of origin, variable measure information or serial numbers are commonly prioritised. This additional data can support recall management, traceability, inventory availability and management, authenticating returns and more.
- **Sustainability or circularity activities:** The information encoded directly into a 2D barcode, along with the information 2D barcodes can direct users to online, can support sustainability and circularity use cases that are key business drivers throughout many markets and may be tied to regulatory activity. Preventing food waste, enabling easier recycling practices and sharing certifications and other details relating to sustainability are some of the 2D barcode transition drivers in this area

For information on what information to put into a 2D barcode to support specific use cases, see Section [5.4](#).

5.2.2 Determining which products to start with

While 2D barcodes using GS1 standards can be introduced at any time, certain scenarios may make the transition to 2D barcodes more manageable.

- **Available packaging space for 2D:** Some products or packages have more space available to add a 2D barcode than others. Creating a list of which products can readily fit a 2D barcode can support determining where to start. Note that until systems are updated to scan 2D barcodes, both a linear and a 2D barcode are required on-pack. For more information on multiple barcode placement, see Section [4.1.2](#).

- **Existing equipment able to create and print 2D:** Not all production lines, printers and other equipment used to apply a barcode to a product are readily capable of producing a quality 2D barcode. Products that have their barcode applied on equipment that is currently capable or will soon be moved to upgraded equipment with such capabilities are ideal to start with.
- **Migration to use of Global Trade Item Number (GTIN):** Companies not currently leveraging the GTIN in a barcode on-pack are commonly migrating to using GTIN. During this migration that requires updates to identification and packaging, incorporating 2D barcode elements may be useful in meeting business needs. How to best migrate to GTIN is dependent on a number of factors, including what identifier is in use (e.g., restricted circulation number (RCN), SKU, etc). For more information, see Section [4.1](#) and contact your local [GS1 Member Organisation](#) for more details.
- **New product launch:** New products offer a great opportunity to include 2D barcodes from the start. Use of QR Code or Data Matrix powered by GS1 Digital Link URI on new products has been cited as useful specifically to connect consumers to content to drive trial, share information on the product with others and meet other marketing objectives related to successful product launches.
- **Packaging redesign:**
 - **Product sold to a limited market:** When initiating a new process, it can be helpful to launch the change in a controlled environment. Some brand owners find it ideal to begin their initial 2D barcode migration on products with limited or seasonal distribution.
 - **Product already using 2D barcodes which are not GS1 compliant:** Products that already have one or more 2D barcodes maybe a natural starting point for transitioning to a single GS1 compliant 2D barcode that can meet multiple use case needs. For guidance, see Section [5.3.7](#).

5.3 Use case scenarios

This section highlights examples of how a single 2D barcode can be applied to support the top reasons why industry is transitioning to 2D barcodes in retail that are outlined in Section [5.2.1](#).

Real-world case studies using 2D barcodes see the [GS1 case study library](#).

! **Important:** There may be other methods and combinations of GS1 Application Identifiers (AIs) used to meet the business opportunity. These examples are not requirements for addressing the use cases highlighted.

5.3.1 Consumer engagement and marketing opportunity use cases

Opportunity overview

A 2D barcode can be an interesting avenue for consumers to interact with a brand. Through scanning of the 2D barcode, consumers might access recipes, social media, augmented reality experiences or anything else a brand may dream up. Connecting with consumer offers unique opportunities to educate and engage in ways to incentivise purchases and build brand loyalty that cannot be accomplished without going beyond what can be on the packaging.

How GS1 standards can help

The GS1 Digital Link URI syntax and [supporting standards](#) provide a structured, scalable way to create a barcode that can meet retail supply chain and consumer needs.

Barcode and syntax considerations

QR Code or Data Matrix with GS1 Digital Link URI syntax would be the most consumer-friendly solutions for consumer engagement use cases. QR Codes containing a URI can be read by mobile devices more readily than Data Matrix. Data Matrix may require an app to be read on some devices.

Other barcodes containing a GTIN, like EAN/UPC, can be used to pull up information via an app, but they will not provide the extremely user-friendly experience seen with QR Code, and to a lesser degree Data Matrix.

Data Matrix may be an ideal choice for product packaging where a QR Code cannot fit.

GS1 Application Identifier (AI) options

Consumer engagement use cases can be successfully achieved using only the GTIN with (01). Additional AIs can be added to enable certain experiences, such as using a batch/lot number to provide more specific traceability information.

What to link to

What the 2D barcode links to is up to the brand owner to determine. What information or experience is best for marketing objectives and meeting consumer needs is dependent on the product type, the company and their market.

Key benefit summary

- Direct and effective consumer engagement
- Increased insights on how consumers are interacting with a product
- Ability to change the digital consumer experience without having to modify the packaging
- Foster brand engagement and loyalty

Examples with various product types

- The barcode on a paint brush set links to tutorial videos on landscape painting.
- The barcode on lambchop packaging links to information details on the farm.
- The barcode on a sparkling water bottle links to a promotion where the consumer can obtain a coupon.
- The barcode on a cleaning chemical links to safe handling instructions.
- The barcode on an eyeshadow palette links to influencers testing the product.
- The barcode on fishing lures links to information on the best places to catch blue marlin.

5.3.2 Packaging design constraints use cases

Opportunity overview

There can be heavy demands made on products that not all packaging can accommodate. 2D barcodes can contain more information in a smaller space than linear barcodes. Additionally, QR Code and Data Matrix leveraging GS1 Digital Link can extend the product packaging to the web where space is no longer a concern.

How GS1 standards can help

GS1 standards offer flexible options for meeting business needs. 2D barcode type options, variable length data and the ability to link to online data using GS1 Digital Link URI can be explored to help meet packaging constraint needs.

Barcode and syntax considerations

If not needing to connect to the web, GS1 DataMatrix using GS1 element string syntax will offer the smallest size of the 2D barcode options for retail. Both GS1 DataMatrix and Data Matrix with GS1 Digital Link URI syntax have rectangular options that can fit places that the square versions and QR Code cannot.

GS1 Application Identifier (AI) options

When size is a concern, it is important to use the fewest number of AIs possible to meet the use case needs. Optimising the contained data by avoiding alphabetic and special characters where possible is ideal. At minimum, the Global Trade Item Number (GTIN) with (01) is required.

What to link to

What is linked to will be based on use case requirements separate from packaging design constraints.

Key benefit summary

- 2D barcodes can fit in much smaller spaces than linear barcodes.
- GS1 Digital Link in QR Code or Data Matrix can readily link to online information to extend the product packaging.

Examples with various product types

- A screwdriver has a QR Code with GS1 Digital Link.
- Chewing gum uses a rectangular Data Matrix with GS1 Digital Link to connect consumers with online information.
- Loose oranges are marked with a GS1 DataMatrix with GTIN and batch/lot number to support traceability.

5.3.3 Regulatory requirements and compliance use cases

Requirements for complying with local or regional regulations will vary, however a GS1 compliant 2D barcode may be able to support those requirements. For example, if product or ingredient information is required and the details can be disclosed digitally, that information could be provided using a QR Code or Data Matrix with GS1 Digital Link URI syntax.

- ✔ **Note:** Transition to the GS1 Digital Link URI syntax on healthcare products is not recommended as GS1 DataMatrix is used to comply with regulatory requirements.

5.3.4 High-risk product category use cases

Opportunity overview

Risk can take many forms across retail products. Some examples of high-risk retail scenarios include product recalls due to defects or contamination, short self-life products, products containing allergens, hazardous materials and commonly stolen or counterfeited product.

How GS1 standards can help

GS1 standards provide ways to provide the granularity and transparency needed to meet a wide array of business needs. Having value-add information in the barcode to be captured and acted upon throughout the supply chain is essential for addressing many high-risk product needs. The data encoded in the barcode on the physical object can tie to digital information captured and shared through other GS1 standards like [EPCIS for event data](#). Providing consumers and business partners transparency through online information using QR Code or Data Matrix with GS1 Digital Link may also support both pre and post-purchase needs.

Barcode and syntax considerations

All the 2D barcode options available for use at retail can support the additional data beyond GTIN many of these products benefit from. If connecting users to the web is not a requirement, GS1 DataMatrix with GS1 element string syntax is ideal. For use cases that benefit from online experiences, use of GS1 Digital Link URI is recommended. Given the high-risk nature of these use cases, QR Code may be a better option than Data Matrix because it can be read by more devices without a mobile app.

GS1 Application Identifier (AI) options

Many high-risk product use cases can benefit from additional identification granularity. Adding batch/lot number (10) and/or serial number (21) helps to track and isolate products. Use of date AIs supports freshness management and can prevent selling goods that are no longer appropriate for sale.

What to link to

When linking to online information specific to the product, details pertaining to the point of risk need to be prominent and easy for users to discover. For instance, if a product may be part of a recall, it is ideal for that information to be one of the first things a user sees when the webpage appears.

Key benefit summary

- Additional data in the barcode allows for key details to be tracked as the product moves through the supply chain and, potentially, post-purchase.
- Linking to web content related to the risk point supports the ability to take appropriate actions to promote streamlining activities and promoting safety.

Examples with various product types

- In-store packaged sushi is labelled with GTIN (01) and date and time of expiration (7003) in a GS1 DataMatrix. At a specific time during the day, retail systems interacting with the barcode and flag the product as expired and stop sale.
- A salad mix is labelled with a GTIN (01) and batch/lot number (10) in a DataMatrix with GS1 Digital Link. Those interacting with the barcode can get details on the farm where the ingredients were sourced from, sustainability information and allergen details.
- Car seats are labelled with GTIN (01) and serial number (21). The serialised GTIN is used to support verifying the product's registration and warranty information. Additionally, when a recall occurs, the impacted car seats can be identified by scanning a 2D barcode containing GS1 Digital Link that informs them whether their product is part of the recall and the appropriate next steps to take.
- Chlorine is labelled with a GTIN-only (01) 2D barcode with GS1 Digital Link. The barcode links users to safe handling and proper disposal instructions.
- Linalool, an allergen, is used in a perfume labeled with GTIN (01) and batch/lot number (10) in a 2D barcode using GS1 Digital Link. With a full list of allergens unable to fit on the product packaging, the QR Code links users to allergen disclosures and certificates of conformity.
- Football jerseys are labelled with GTIN (01) and serial number (21). These products are tracked throughout the supply chain where both the GTIN and serial number are captured. At retail point-of-sale, the serial number is also captured. Based on the serialised GTIN, a product's authenticity can be verified. In a situation where the product is returned, it can be confirmed that it was a product sold through that sales channel.

5.3.5 Supply chain or retail need

Opportunity overview

GS1-complaint 2D barcodes can offer benefits to all parts of the retail supply chain that go beyond opportunities to enable consumer engagements. Retailers can benefit from using the data in 2D barcodes to enable functionality to provide unique benefits. Reading data beyond the GTIN on supplier products, designing their own private label products or creating in-store labelling for fresh foods, having the right data can unlock value.

How GS1 standards can help

2D barcodes are capable of encoding data that can support a wide variety of information to support supply chain and retail needs, while also working towards keeping consumers safe and satisfied. This support includes recall management, traceability, inventory availability and management, authenticating returns and more. The value of the information in the barcode grows when paired with other standards related to the product and how it is transacted with.

Barcode and syntax considerations

All the available 2D barcodes available for retail use can add value. If not needing to connect to an online experience, GS1 DataMatrix with GS1 element string syntax is ideal. If a web experience is needed, a QR Code with GS1 Digital Link or Data Matrix with Digital Link should be used.

GS1 Application Identifier (AI) options

Retailers and others interacting with barcodes can enable AIs beyond GTIN (01) to be read by their systems based on their business priorities. Commonly prioritised are batch/lot numbers, dates, country of origin, variable measure information and serial numbers. See Section [5.4.1](#) for details on common AIs used in retail.

What to link to

When the use case is specific to retail needs and do not have a consumer engagement component, there may not be a need to link to anything. There can be business-to-business information that retail staff are connected to, such as safe handling or disposal instructions. For supply chain, which AIs are best will vary based on the need. More granular identification on the products being interacted with can be accomplished with consumer product variant (22), batch/lot number (10) and serial number (21). AIs related to date and origin may also be of value based on business goals.

Key benefit summary

- More granular identification of products supports isolating products with issues, confirming authenticity of products and managing inventories.
- Including date information in barcodes supports efficient inventory and freshness management.
- More information in the barcode helps satisfy traceability, provenance and ethical sourcing needs.

Examples with various product types

- At the deli counter, bologna is sliced based on consumer request. The GTIN for the item (01) along with variable measure attributes for weight (320n) and price (390n) are printed in-store in a GS1 DataMatrix barcode. The GTIN allows for persistent identification of the item while the other AIs allow for the specific weight and price to be captured and correctly charged for during checkout.
- Wet dog food can packaging is updated to include an image of the famous dog, George. This does not require a new GTIN based on the [GTIN Management Standard](#), so consumer product variant (22) is added to the GTIN (01) in a Data Matrix using GS1 Digital Link. This allows for the right data associated with the variant to be pulled throughout the retailer's ecosystem and data specific to the sale of the George variation to be captured and acted upon.
- A luxury handbag is labelled with a QR Code with GS1 Digital Link containing GTIN (01) and serial number (21). When sold, the GTIN and serial number are captured during the transaction and can be used to validate and expedite a future return.

5.3.6 Sustainability and circularity activity use cases

Opportunity overview

Sustainability and circularity offer significant opportunities to companies across all sectors adapting to new business processes and requirements. Having more data tied to products throughout their lifecycle and greater transparency and education available to consumers helps to improve sustainability across the value chain.

How GS1 standards can help

GS1 standards enable organisations to identify, capture and share information smoothly, creating a common language that underpins systems and business processes. It enables interoperability between information systems, ensuring that data can flow between trading partners and downstream to the consumer. Having key information in 2D barcodes on products can tie to digital information needed to support sustainability and a circular economy.

Barcode and syntax considerations

While having more data in the barcode is useful for many sustainability use cases, offering a web-friendly experience is hugely valuable, making a 2D barcode using GS1 Digital Link ideal.

GS1 Application Identifier (AI) options

As with other use cases, adding further granularity to the GTIN (01) using batch/lot number (10) and/or serial number (21) can add value by providing details specific to the products being interacted with. Country of origin (422) and Global Location Number of the product or service location (416) can be useful for use cases that need location information captured automatically with the barcode scan. Date AIs can be extraordinarily beneficial for loss reduction and to promote freshness management.

What to link to

When using GS1 Digital Link, connecting users to sourcing information, certifications, details on how to recycle – or upcycle and how the product is part of a sustainable supply chain.

Key benefit summary

- Having more actionable information in barcodes can help bring waste back into the value chain by enabling recycling and other reuse of products.
- Managing fresh product effectively through use of dates prevents food waste.
- Providing easy to access, transparent information to businesses and consumers supports sustainable practices.

Examples with various product types

- A sneaker has a QR Code with GS1 Digital Link containing a GTIN (01) and serial number (21) on both the box and sewn into the inside of the shoe. This allows the sneakers to be tracked for authenticity, while also allowing information about the product to be shared. For instance, the QR Code may link to information about material sourcing, ethical labour practices and how to recycle the product.
- Prepared apples are labelled with a GS1 DataMatrix with a GTIN (01) and best before date (15). When the best before date is reached, the product is pulled from shelves and transformed into baked goods and then relabelled to prevent food waste.
- Variable weight crab legs are labelled with a QR Code using GS1 Digital Link and GTIN (01), batch/lot number (10), net weight (310n) and an expiration date (17). The product closest to the expiration date can be rotated for sale first. Additionally, automatic price markdowns could occur to incentivise consumer purchases. Those scanning the QR Code might get details on sustainable fishing practices, where the product was sourced from and delicious recipes.



Note: There are use cases for using GS1 identification keys beyond GTIN to support sustainability use cases. For example, use of the Global Returnable Asset Identifier (GRAI) to track refillable beverage containers, reusable containers and returnable shopping bags are emerging in retail environments. Contact your local GS1 Member Organisation for more information.

5.3.7 Transition from 2D barcodes not using GS1 standards

It is not uncommon for a retail product to already have a 2D barcode on-pack that does not use GS1 standards. Most often, existing 2D barcodes are used for consumer engagement or internal operational purposes such as packaging identification, anticounterfeiting and shelf-life management.

- **Consumer engagement:** These barcodes are used to offer a variety of experiences to consumers.
 - **URL:** Transitioning from a general URL to one using the GS1 Digital Link URI syntax is an ideal starting point for many brands looking to migrate to a standardised 2D barcode. A 2D barcode using GS1 Digital Link URI syntax can be a gateway to the same experience as currently exists, with the added benefit of having GTIN and optional additional data encoded that can be used by retailers to enable more use cases. Transitioning to the GS1 Digital Link URI syntax may impact the overall size of the barcode due to the change in the data structure.
 - **Loyalty programme or promotion symbol:** Products that contain a proprietary barcode or symbol that is scanned using an application. GS1 Digital Link URI syntax can connect consumers to the same content through use of an application or, in some cases, using the default camera on their mobile device.
 - **Other proprietary symbols:** There are a wide array of other uses for proprietary barcodes and other symbols, such as but not limited to supporting those with visual impairments or meeting market-specific requirements. For support on how GS1 compliant barcodes may be able to support these use cases, contact your local GS1 Member Organisation.
- **Internal operations:** These barcodes contain data that is not intended to be used by the consumer, retailer or other trading partners.

- **Packaging component indication:** Products might use 2D barcodes to ensure the right label, lid or other component is properly attached to other packaging components. There is a GS1 Application Identifier (AI) that can be used for this purpose. Packaging Component Number (243) may be a viable option to combine multiple barcodes used for different purposes into one. Merging a packaging barcode may present some challenges based on how it is used during the manufacturing process. When the packaging component barcode is placed and used may come before the retail POS barcode is applied. Additionally, where the retail barcode is placed may not be appropriate for where the packaging component barcode needs to be positioned for manufacturing processes. Lastly, systems may require updates to recognise and act on AI (243).
- **Internal identification:** Products are sometimes labelled with SKUs, customer number, or other means of identification. Some products are labelled with an EAN/UPC barcode encoding a Restricted Circulation Number (RCN) that is 12 or 13 digits long. When used with variable measure products, the RCN may contain information about the weight or price of the variable measure item. An RCN is, at best case, unique at a national level. An RCN is not a GTIN (Global Trade Item Number) and is not able to be encoded into a GS1 compliant 2D barcode in place of a GTIN.
- Use of GS1 Application Identifier (240) for additional product identification assigned by the manufacturer may support incorporating the internal identifier into the same barcode as the GTIN during a transition period, but this is not applicable to RCNs, as RCNs are not permitted to be encoded with GS1 Application Identifiers.

5.4 What goes into the barcode?

An important driver for the transition to 2D barcodes is the ability to retrieve more data from a single scan. There is significant flexibility in the data that can be included in a 2D barcode. This allows for a wide range of use cases to be served by a single barcode without needing to include a significant amount of data in the 2D barcode itself. Adding any new data field will have practical implications. For example, including dynamic data that is different for various instances of a trade item may rule out pre-printing the barcode in some cases. Any addition of data will also make the 2D barcode physically larger.

Two questions to ask when deciding what to include in the barcode are:

1. Is this data necessary to identify the product at the required level of granularity for action to be taken when needed?
 - For example, a GTIN, batch/lot number and sell-by date may be needed at retail point-of-sale (POS) during the consumer check-out. This allows for price look-up to take place, items beyond the sell-by date to be processed accordingly and the batch/lot number to be captured and associated to the consumer's loyalty program.
2. Rather than encoding it in the barcode, could an online lookup or other means be used to find the information?
 - In the above scenario, information relating to the product's production date and location can be accessed based on the batch/lot number and sustainability information important to consumers could be linked to using GS1 Digital Link.

! **Important:** If the business need can be satisfied by looking up the required data online, or via the retailer's in-store system, leave the data out of the barcode. This is especially true for 2D barcodes that include the GTIN and serial number. Given that unique identification at the instance level, everything else can be looked up *if an* internet connection is available.

5.4.1 GS1 Application Identifiers used in retail

This section highlights different types of data that can be included in a 2D barcode using GS1 Application Identifiers (AIs). This list is not exhaustive. For the full list of GS1 Application Identifiers, see Section 3 of the [GS1 General Specifications](#).

■ Primary identification

- **Global Trade Item Number (GTIN) (01):** Used to uniquely identify the trade item.

- **GS1 identification key qualifiers**
 - **Consumer product variant (CPV) (22):** CPV may be used to distinguish one variant of a retail consumer trade item from another if the change does not require the allocation of a different Global Trade Item Number per the GTIN Management Standard, but communication between trading partners is required to support consumers. The brand owner is responsible for assigning the consumer product variant.
 - **Batch/lot number (10):** The batch or lot number associates an item with information the manufacturer considers relevant for traceability of the trade item to which the element string is applied. The data may refer to the trade item itself or to items contained. The number may be, for example, a production lot number, a shift number, a machine number, a time, or an internal production code. In cases where the same product is manufactured in different locations the brand owner and the manufacturer are responsible for ensuring the non-duplication of batch/lot numbers for a GTIN.
 - **Serial number (21):** A serial number is assigned to an entity for its lifetime. When combined with a GTIN, a serial number uniquely identifies an individual item. The brand owner and the manufacturer are responsible for ensuring the non-duplication of serial numbers for a GTIN. Serial number is most useful on products that need exact tracking as they allow every instance of the product to be individually identified.
- **Variable measure attributes** are used only with products that have some element that changes and that impacts how the product is purchased. These are most commonly used with fresh products, like meat, seafood, produce and baked goods. Variable measure products also exist in construction/DIY, hobby and other product types.
 - **Count of items (30):** The number of items contained in a variable measure trade item (e.g., apples, bolts)
 - **Net weight in kilograms (310n):** This is used to represent total weight of the product being sold. (e.g., 5.5 kg of salmon)
 - **Net weight in pounds (320n):** This is used to represent the total weight of a product being sold. (e.g., 100 lb red lava rock)
 - **Amount payable AIs** are used to by POS systems to charge the correct amount to the consumer.
 - Amount payable for a variable measure trade item – Single monetary area (392n)
 - Amount payable for a variable measure trade item and ISO currency code (393n)
 - Amount payable per unit of measure single monetary area (395n)
 - **Other variable measure AIs** are available for trade item measure details. These can be used for things like length of fabric, area of carpet or grass turf sold and the net volume of beer in gallons.
- **Dates** are primarily used to help ensure freshness, maintain on-shelf availability and promote consumer safety.
 - **Production date (11):** This is the production or assembly date determined by the manufacturer. This can support stock rotation and inventory management.
 - **Packaging date (13):** This is the date when the goods were packed as determined by the packager. This can support stock rotation and inventory management of packaged items.
 - **Best before date (15):** A best before date on the label or package signifies the end of the period under which the product will retain specific quality attributes or claims even though the product may continue to retain positive quality attributes after this date.
 - A retailer may use this to determine a date after which they will no longer merchandise the product. Currently, there are implementations of best before date which are interpreted in their processes as the date to sell by.
 - **Sell by date (16):** This date is specified by the manufacturer as the last date the retailer is to offer the product for sale to the consumer. The product should not be merchandised after this date.

- **Expiration date (17):** This is the date that determines the limit of consumption or use of a product/coupon. Its meaning is determined based on the trade item context. For example, with food products, the date will indicate the possibility of a direct health risk resulting from use of the product after the date. It is often referred to as "use by date" or "maximum durability date."
- **Expiration date and time (7003):** The manufacturer determines the expiration date and time, which is relevant only for short duration and for items that will not be sent on long distances and not outside of the time zone. This is used for extremely time sensitive items that must be prevented from being sold at a specific time of the day.
- **Production date and time (8008):** The date and time of production is determined by the manufacturer.
- **Sourcing information**
 - **Global Location Number (GLN) of production or service location (416):** The GLN is used in combination with a GTIN to specify where the product was produced or serviced. The information associated with the GLN in a database or other locations provides details on that location. This may be used when a GTIN is provided at multiple facilities where country of origin is not detailed enough, and the information cannot be associated to a batch/lot number or serial number.
 - **Country of Origin (422):** The country of origin is normally the country in which the trade item has been produced or manufactured. In meat supply chain applications (422) it is used to indicate the country of birth of the animal. Due to a wide range of definitions for country of origin, which were created for different purposes, it is the manufacturer's responsibility to assign the correct country of origin.
- **Company specific AIs**
 - **Additional product information assigned by the manufacturer (240):** This AI enables identification data other than the GTIN to be represented in a GS1 system data carrier. It is a cross-reference to previously used catalogue numbers. The additional item identification is considered an attribute of the GTIN as it facilitates migration to the GS1 system during a transitional period. It must not be used to replace the GTIN.
 - **Customer part number (241):** This is used to enable identification data other than the Global Trade Item Number (GTIN) to be represented in a GS1 system data carrier. The element string SHOULD only be used between trading partners that are currently using the customer part number for ordering and who have agreed on a timetable to convert to the GTIN for their business purposes. The use of the GTIN and customer part number (241) on trade items is for transitional use during the conversion. The customer part number must not be used in place of the GTIN, nor for encoding RCNs.
 - **Packaging component number (PCN) (243):** A PCN is assigned to the packaging component for its lifetime. When associated with a GTIN, a PCN uniquely identifies the relationship between a finished consumer trade item and one of its packaging components. The PCN is for internal use.
 - **Company internal information (91-99):** This range of AIs supports up to 90 alphanumeric characters and can be used for any application needed within the organisation, with the exception of encoding RCNs which are not permitted to be used with AIs. These AIs are not intended for use in an open supply chain and are viewed as options to support transitioning to standardised AIs when no other option exists. As these AIs are defined for use by individual organisations for their own operations, how systems interact with them will greatly vary. These AIs SHOULD be removed from any item that leaves the jurisdiction of the organisation.

5.4.1.1 Using GS1 element string syntax

GS1 element string syntax is available for use with GS1 DataMatrix barcodes. This is the same data format as seen with GS1-128 and GS1 DataBar Expanded varieties and may already be available in retail systems. GS1 element string syntax is ideal for use cases that require a smaller barcode or require more information beyond the Global Trade Item Number (GTIN) but without the need to readily connect consumers to an online experience using the camera on their mobile device. Some

companies may not be ready to create online content to link to or have the need for it. In some cases, regulations may specify the use of GS1 DataMatrix for certain product types.

For more information on GS1 element string syntax, see Section [4.5](#) GS1 barcode syntaxes used in retail POS.

5.4.1.2 Using GS1 Digital Link URI syntax

GS1 Digital Link URI syntax is used in either QR Code or Data Matrix. This data format takes the same GS1 Application Identifiers (AIs) used in GS1 element string syntax and puts them in a web-friendly format. Brand owners select barcodes that use GS1 Digital Link URI to support use cases that connect consumers to online information. This can be a GTIN-only barcode or GTIN with additional AIs, like batch/lot number or serial number. In some cases, a regulation may specify the use of barcodes that can link consumers to information for certain product types.

In addition to the GTIN and optional AIs, the GS1 Digital Link URI contains a domain name that is determined by the brand owner. For more information on GS1 Digital Link URI syntax, see Section [4.5](#) GS1 barcode syntaxes used in retail POS.



(01)09524810000339

Figure 5-1 Example of QR Code with GS1 Digital Link URI data string:
<https://example.com/01/09524810000339/10/YA12AB?17=271231>

For the GS1 Digital Link URI to take a consumer to information, the full data string, including the domain name must be set up to redirect the user to pre-existing content.

For more information on these topics see:

- [Best practices for creating your QR Code powered by GS1](#): Provides a high-level overview of the key points in creating a GS1 Digital Link URI and its use.
- [Connecting barcodes to related information](#): Provides details on the multiple methods to maximise the functionality of a GS1 Digital Link 2D barcode.
- [GS1 Digital Link quick start guide](#): practical guidance aimed at implementers with some familiarity of web technologies.

5.5 Selecting which barcode to use

Multiple 2D barcode options exist as they are designed to meet different needs. When assessing how to best progress towards globally standardised use of 2D barcodes across retail, stakeholders agreed that three options were needed and could meet their collective needs.

- **GS1 DataMatrix with GS1 element string syntax**: Best for use cases that do not require full web compatibility, but a smaller barcode than the linear options and/or additional data beyond the Global Trade Item Number (GTIN) is needed.
- **QR Code with GS1 Digital Link**: Best for use cases with requirements for consumer engagement and full mobile device compatibility.



Figure 5-2 QR Code with GS1 Digital Link URI

- **Data Matrix with GS1 Digital Link:** Can be for use cases with requirements for consumer engagement and limited space. Data Matrix is not fully compatible with mobile device default camera app.



Figure 5-3 Data Matrix with GS1 Digital Link URI

- ! **Important:** Much like transitioning from linear to 2D barcodes, it is possible to change between 2D barcode types and change the type of data included in the barcode as use cases evolve. While it may be ideal to only change the barcode being used once, it can change more over time based on use case needs. Once updated, retailer systems will be able to read GS1 DataMatrix with GS1 element string syntax and QR Code and DataMatrix with GS1 Digital Link URI syntax.

For more information on barcode features, see [4.2](#).

5.5.1 Dual-marking with a linear and 2D barcode

During a transition period, products leveraging a 2D barcode are still required to have a linear barcode on-pack. This requirement is due to retailers and other business partners being unable to read 2D barcodes without system updates. Retailers must enable the capability to GS1 compliant 2D barcodes before linear barcodes can be removed. Removing the linear barcode prematurely might result in no readable barcode being on-pack, manual data entry and errors, massive delays at point-of-sale, poor consumer experiences and more.

As linear barcodes cannot be removed until 2D capabilities are enabled across retail, some products will be unable to fit both the linear and 2D barcode. As a result, these products may have to wait until linear barcodes are no longer required and use other means to engage with consumers and supply trading partners with additional data.

See Section [4.1.2](#) Placement and multiple barcodes for more information.

5.6 Barcode placement and human readable text

Brand owners and manufacturers have options available when it comes to where to place the barcode and how to display the text relating to what the barcode contains. This section provides barcode placement and human readable text options. See Section [4.1.2](#) for general guidance on barcode placement and human readable text. Standards on 2D barcode placement and human readable text can be found in the [GS1 General Specifications](#).

5.6.1 General examples

These examples represent common barcode placement options.

- **GTIN-only** 2D barcodes can be used



Figure 5-4 Example of GTIN only location

- **GTIN with a date:** Where the human readable text related to the **date** is located and how it is formatted can vary.

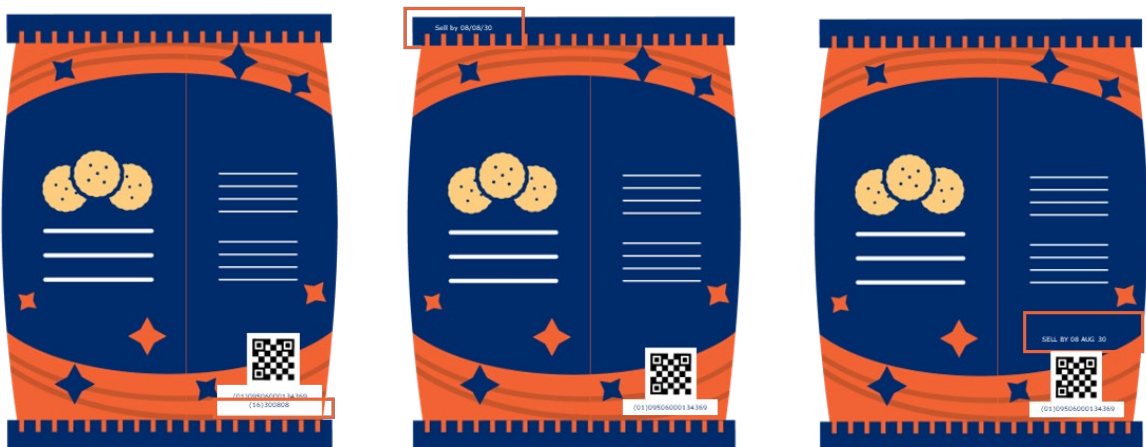

Figure 5-5 Examples of date locations

GTIN with batch/lot number and serial number: Where the human readable text related to the data beyond GTIN is located and how it is formatted can vary.



Figure 5-6 Examples of Batch/lot and serial number

- **GTIN with consumer product variant (CPV):** Where the human readable text related to the CPV is located and how it is formatted can vary.

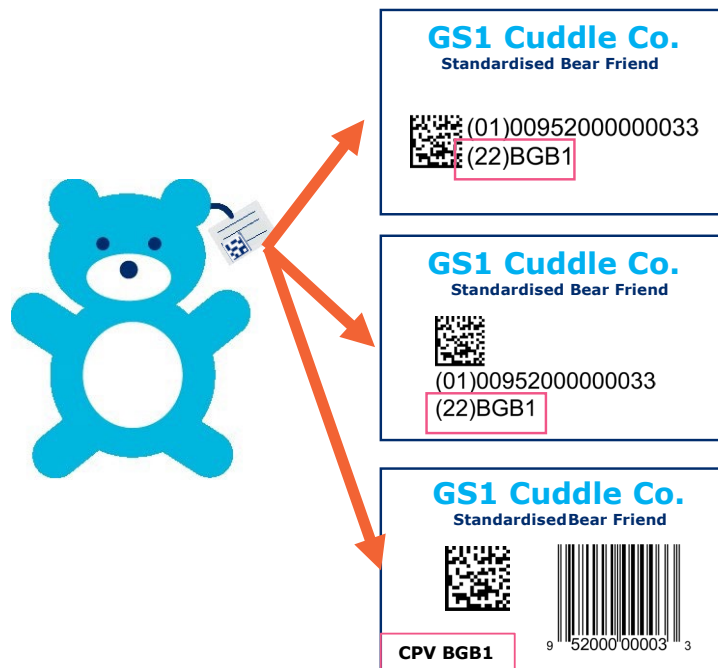

Figure 5-7 Example of consumer product variant

- **GTIN with packaging component number (PCN):** As a PCN is for internal use only, the information does not have to appear on the label.



<https://example.com/01/0952000000097?243=V935>

Figure 5-8 Example of Packaging component number

5.6.2 2D barcode used for marketing purposes

In some use cases, the 2D barcode is being added for marketing purposes with a sole focus on consumer engagement. These barcodes tend to contain only the Global Trade Item Number (GTIN) using the GS1 Digital Link URI syntax and would be in addition to a GS1 compliant linear or 2D barcode placed for retail point-of-sale (POS) use. These barcodes may be placed on a front or side panel separate from the POS barcode and do not require human readable text as shown below.

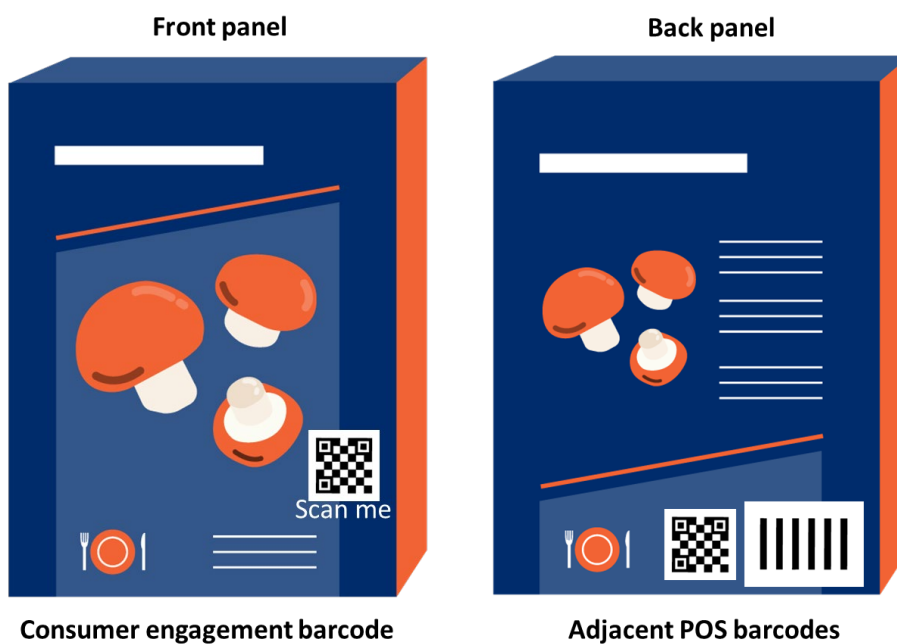

Consumer engagement barcode

Adjacent POS barcodes

Figure 5-9 Example of consumer engagement 2D barcode on front panel

Putting a 2D barcode on a different quadrant of the same panel as the POS barcode may result in both the consumer engagement and POS barcode being captured. Therefore, causing unintended POS transactions.

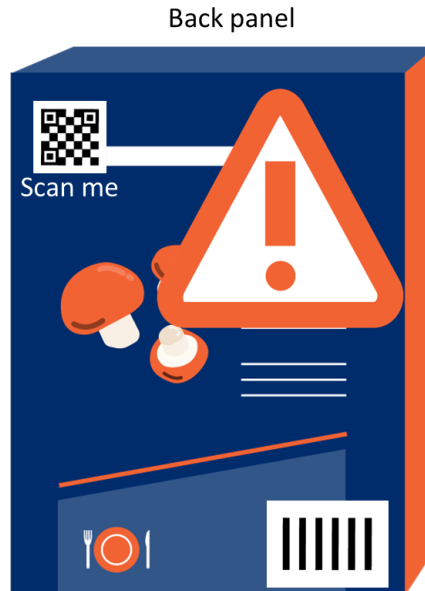

Figure 5-10 Example of consumer engagement 2D barcode on back panel

5.6.3 Placing barcodes on adjacent sides

Some brands and manufacturers may select to place barcodes on adjacent sides of a package to support a variety of use cases. For example, use of barcodes on adjacent panels could be a result of how the product is merchandised, how consumers engage with the panels or allowing larger products to be more easily scanned throughout the supply chain and at POS. The key point on this is to place the barcodes at a distance where barcodes scanners will be able to capture the multiple barcodes close enough to be able to determine they are on the same product and prevent a double-scan from occurring. While this is not an issue with use of presentation or handheld scanners, there is a chance bi-optic scanners that view the product from multiple angles at once could. Placing the barcodes close to each other on adjacent panels can support the systems recognising the barcodes are on the same product and process accordingly.

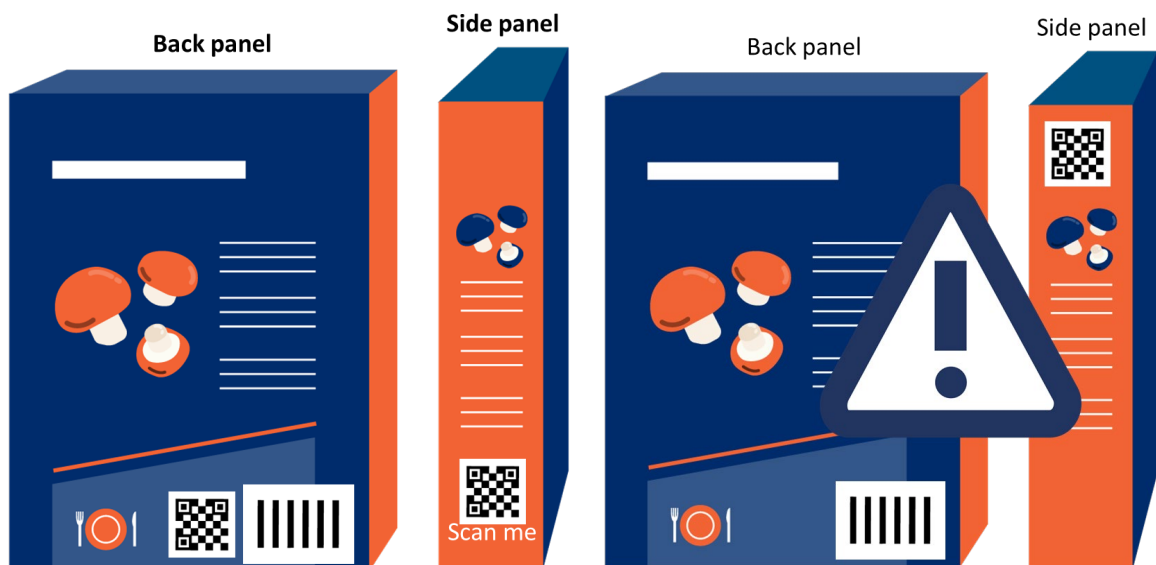

Figure 5-11 Example of barcode placement on adjacent panels

5.6.4 Fresh products

The shape of types of produce and the variations within a single product type can create challenges when adding any barcode. These products may also benefit from variable measure information encoded in the 2D barcode.



Figure 5-12 Examples of fresh products

5.6.5 Hang tags

Products leveraging hang tags use different layouts than other packaging. It is also relatively common for hang tags to incorporate RFID tags. Below are examples of two hang tag options and a 2D barcode that could be permanently on the inside shirt collar.



Figure 5-13 Apparel hang tags and thermal labels

5.6.6 Large, heavy or bulky items

There are existing barcode placement rules for large, heavy or bulky products that are outlined in Section 6.4.9 of the GS1 General Specifications. This content defines large, heavy or bulky items as

450 millimetres (18 inches) or more in any two dimensions and/or weighing in excess of 13 kilograms (28 pounds). For these products, the standard states barcodes SHOULD be placed on the opposing sides of the product as shown below. This allows for barcodes to be more readily accessed for scanning.



Figure 5-14 Example of a large product

5.6.7 Use of text or symbols to promote barcode interactions

There are no GS1 standards that require or recommend having a callout on the packaging to scan a barcode. This is left purely to the discretion of the brand owner to determine if adding a callout makes sense for their product and target audience.

5.6.8 Where 2D barcodes cannot be used

Not all products and packaging are able to properly accommodate a 2D barcode. Some products, like those that are very thin or cylindrical, do not have enough space for the full, square 2D barcode to be captured. Unlike their linear counterparts that only require a single scan line to process, 2D barcodes require the entire symbol to be captured to reliably read the barcode. Within the GS1 system there are smaller rectangular forms of GS1 DataMatrix and Data Matrix that could be considered which might be capable of being reliably read. Figure 5-15 below shows a product with a 2D barcode that could not be read.

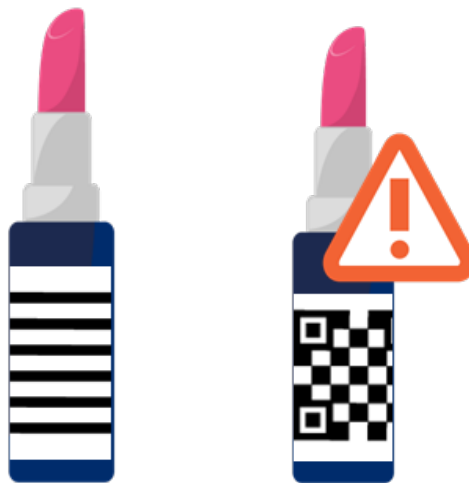

Figure 5-15 Example of a cylindrical product

During the 2D barcode transition period that requires both a linear and a 2D barcode to be present, the 2D barcode may not fit and therefore a linear barcode must be used until systems are updated to the point where the linear barcode is no longer required.



Figure 5-16 Example of a small product

5.7 Creating and printing 2D barcodes

5.7.1 Barcode creation

Creating a 2D barcode for retail use is similar in many ways to creating linear barcodes. The type of barcode, data to encode and sizing must be known. Additionally, the barcode needs to be compatible with the equipment used to apply the barcode and the product materials it is being applied to.

Quality barcode software for creating GS1 compliant barcodes normally will format the data, optimise the encoding and include the appropriate Quiet Zone automatically based on what the user, or supporting system, has entered. Problems occur when barcode software does not automatically do things such as insert the function code one (FNC1) in GS1 DataMatrix, allow invalid characters or otherwise not follow the barcode symbology or GS1 barcode syntax requirements (i.e., GS1 Application Identifier structures or associations). When assessing existing or new barcode creation software, it is critical to investigate if the solution is designed to create all barcodes and syntaxes that will be required by the organisation and in a manner that complies with GS1 standards.

There are key differences between creating linear and 2D barcodes relating to quality and dynamic data that are explained in the following sections.

For detailed, technical information relating to barcode creation, see Section [7.3](#).

5.7.2 Barcode print quality and verification

Any system or person interacting with a barcode must be able to interact with the barcode quickly and extract the appropriate data for their needs. Poor quality barcodes cause negative experiences in both business and consumer settings. When a barcode is difficult or fails to scan throughout the supply chain, there are delays, costs and other consequences from not being able to capture and act on the encoded data. For consumers, if a barcode does not provide the expected results, they can view the experience as being negative and associate that with the product or brand.

Barcode quality in the GS1 system is based on a combination of ISO/IEC technical specifications and the standards outlined in the GS1 General Specifications. Verification is highly recommended to confirm the barcode's quality and likeliness that it will be read as intended.



Important: Barcode verification does not do any validation on how or where a 2D barcode directs a user to a web experience. Separate processes must be set-up to confirm this.

The following is an overview of barcode quality concepts that summarise what is found in these normative references. For additional technical guidance, see Section [7.2.1](#).

- **Correct sizing:** Height, width and X-dimension sizes all matter. If elements of the barcode are too large or too small, equipment may have difficulties reading the barcode.
- **Distinct contrast:** GS1 DataMatrix, Data Matrix and QR Code are all designed to be a mix of light and dark modules. Systems must be able to distinguish between the light and the dark to recognise and decode the barcode for use. If the colours are too similar, the barcode cannot be easily read and may fail.
- **Appropriate reflectance:** A barcode with highly contrasting colours will still have issues if the light reflecting on the barcode prevents the light and dark pattern from being recognised. Common examples would be high-gloss materials, plastic overlap, or direct part marking on shiny materials.
- **Uniformity:** Even, crisp modules in a perfect grid make for a quality 2D barcode. Ink bleed, inconsistent substrates (e.g., recycled materials with "specs") and off-axis grids are common examples of poor uniformity.
- **No damage or defects:** Whether it happens when the barcode is being applied or after the fact, if it gets smeared, gouged, scraped or otherwise damaged, the quality will be negatively impacted.
- **Conformance to the symbology specification:** Barcodes have elements that are mandatory based on their technical specifications. Examples include ITF-14's bearer bars, finder patterns and correct use of FNC1, plus the 2D barcodes function best with a specific amount of error correction. Barcodes are designed to be used with these elements, and without them, they simply will not work.

5.7.2.1 Use of images, colour and other modifications in 2D barcodes

All types of barcodes, including 2D barcodes, have detailed specifications and requirements that support their consistent, reliable performance. The shapes, colours and patterns that make up a barcode symbol are all very important for it to be successfully read. When there is a desire to modify the barcode to insert an image, colour, change to module shape or other alteration, problems can occur for both consumers and retail systems interacting with the barcode. See Section [4.6.5](#) for more information.

5.7.3 Dynamic data and barcode creation

If an implementation is going to require the encoding of changing, dynamic data, consideration of how this will impact barcode creation is important. Specifically, encoding dynamic data may limit the ability to create barcode labels or packaging material in advance. For more information on this topic see Section [4.7.3](#)

5.7.4 Barcode printing

How successfully 2D barcodes can be printed using existing printing and processes depends on several factors that require extensive internal conversations across stakeholders. What information will go into the barcode and when that information will be known, how the barcodes are generated, line speed requirements, what printing technologies are currently in use, where the barcode(s) will be placed and more must all be known and assessed when creating a 2D barcode transition plan. In many situations, 2D barcodes can be created using existing equipment, but this is not always the case.

It is recommended that brand owners or manufacturers assessing printing capabilities for 2D barcodes start by gathering internal stakeholders and solution providers to determine what equipment currently exists and what, if any, upgrades are required. For example, if the 2D barcode is to include variable data, such as a batch number or best before date, its production may need to take place in real time on a production line. Pre-printing of packaging may not be possible, and users will need to consider which technologies are most appropriate.

For detailed, technical information relating to printing, see Sections 6.8 and 8.



5.8 Digital content creation and management

Connecting consumers and business users to information and experiences is a key driver for the use of 2D barcodes with GS1 Digital Link URI syntax in retail. What content is linked to can vary widely from company to company and even from product to product within a single organisation’s offering.

This section will highlight key concepts for those getting started with GS1 Digital Link URI. Extensive GS1 guidance exists to support using GS1 Digital Link URI syntax in QR Code or Data Matrix to link to web content.

- Redirecting:** What is encoded in the barcode and where scanning the barcode leads are different URIs/URLs. What is encoded in the barcode redirects the users to an existing website or other digital content related to the product. This is a practice that commonly takes place on the web now – the only difference with the use of GS1 Digital Link URI is that the process starts with a barcode instead of a clickable link or by entering information into a search bar. When switching from a proprietary URI to a GS1 Digital Link URI version, use of a redirect can take whoever is scanning the barcode to the same place as the existing barcode, but now with the added benefit of being able to be used at retail point-of-sale for price look-up and other functions.

Table 5-2 URL examples

Example Type	URL example	Could all be redirected to:
URL not in barcode	http://www.example.com/uniqueLink	https://www.example.com/
QR Code not using GS1 standards	 https://www.example.com/ultimatepromotion	
QR Code with GS1 Digital Link	 https://example.com/01/09506000134352?17=301231	

- Changing what the user is redirected to:** After a 2D barcode using GS1 Digital Link URI is added to a product package, what the barcode directs users to can change. In the above scenario, the general https://www.example.com could change to something about a recall, limited time promotion or other content based on the need. This is simply redirecting to a different end point and is done with web links all the time. This means that the barcode can stay the same while the information or experiences the user gets can change.

- **Having one barcode that can lead to multiple places:** By using standardised link relation types, links between items and information about them are machine discoverable. The machine in question – the one that makes links of different types discoverable and actionable is called a resolver. A resolver can make use of features of the web that people use every day. One of its most powerful features is a web server’s ability to show different things to different people at the same time. For example, product information pages can automatically populate in different languages based on a user’s location or device settings, a promotion can be presented only in areas where the product is sold, or a different experience can be presented only at nighttime. While this sort of set-up has more elements than a simple redirect, it is also a practice already heavily in place with the only difference now is that it can use GS1 standards to increase its efficiency and ability to be used at scale.
- **Use of apps:** GS1 standards do not define how to use an app with GS1 barcodes or GS1 Digital Link URI syntax. With use of an app, information pulled from standardised barcodes can be used to create unique experiences within the application. This can use the link types, combinations of data, or simply the GTIN pulled from any barcode. For instance, an app can use the Global Trade Item Number (GTIN) and associated link types to populate a nutrition information and/or recipe within a lifestyle app.

For more information on these topics see:

- [Best practices for creating your QR Code powered by GS1](#): Provides high-level overview of the key points in creating a GS1 Digital Link URI and its use.
- [Connecting barcodes to related information](#): Provides details on the multiple methods to maximise the functionality of a GS1 Digital Link 2D barcode.
- [GS1 Digital Link quick start guide](#): practical guidance aimed at implementers with some familiarity of web technologies.
- Access online information for healthcare products with the existing GS1 Barcode (2023) (https://www.gs1.org/sites/gs1/files/2023-08/accessing-online-product-information-with-the-gs1-digital-link-standard_1.pdf): Provides guidance about accessing online information for healthcare products without adding a QR Code or Data Matrix.

6 Implementation guidance for retailers

This section provides guidance specific to retailers implementing 2D barcodes, to help them understand business opportunities, changes to existing processes or the introduction of new processes and the requirements to ensure success throughout all phases of 2D barcode migration. This guidance is intended to be applicable to all types of retailers, from small, independent businesses all the way through to large multinationals.

The guidance in this section for retailers is focussed on the barcodes produced in-store for goods produced, processed or compiled within the store environment, for example freshly baked bread, roast chickens, sliced fruit etc., and includes references to the General Guidance in Section 4 and Solution Providers in Section 7. For retailer owned-brand guidance, please refer to Section 5 for Brands and Manufacturers Implementation Guidance.

As 2D barcodes have larger data capacity than traditional linear barcodes used at retail point-of-sale (POS), the possibility of encoding GTIN and additional data enables use cases for in-store and online, which are not possible with the GTIN alone. This creates changes to processes at POS, as well as the management of in-store inventory, online fulfilment and product safety for example.

These changes require coordination across all parties involved in the retail supply chain. Stakeholders within the retailer’s own environment, such as staff and leadership teams also need to be involved throughout the planning, testing and deployment framework, with clear understanding of impact to the retailer’s environment and business processes.

While enabling 2D capabilities and understanding technical specifications are important for 2D implementation, it is also critical that retailers understand what to do with the additional data provided by 2D barcodes, in order to unlock new use cases.

Some examples include, but are not limited to, the following:

- Enabling food safety and product traceability

- Improving efficiencies for inventory management and forecasting for in-store production and/or online fulfilment
- Waste management, such as for expired stock and improving stock availability
- Ability to enable different price points for the same trade item, where consumer or promotional variants exist (e.g., wine vintages)
- Enabling facilitation of sustainability targets
- Addressing business efficiencies such as reduction of manual intervention, time/labour management and optimal scan rates
- Enabling access to digital content for consumers such as traceability information, nutritional information, recycling instructions, product certification, country of origin information and much more

6.1 Transitioning to 2D Barcodes

Enabling 2D barcode capabilities in retail requires a clear understanding to identify the who, what and when of 2D barcode implementation.

Who: Section [6.3](#) outlines who amongst retailer roles are responsible for 2D implementation, including information on responsibilities that may overlap or be conditional on other roles. Key “who” questions include:

- Who makes the decision(s) to implement 2D?
- Who is required to take action?
- Who, internally and externally, are impacted by these changes?

What: For the “what” of 2D barcodes for retailers, see Section [6.4](#) for details on the various touchpoints that may be impacted and/or benefits from 2D implementation and Section [6.6](#) on what goes into the barcode to explore use cases to solve problems or provide efficiencies and improvements. Key “what” questions include:

- What is in and out of scope of the 2D implementation project?
- What product categories or ranges will be selected for pilot and first phase deployments (e.g., branded or own-brand, fresh foods or shelf stable etc.)
- What parts of the retail ecosystem are impacted?
- What use cases need to be unlocked to achieve the desired benefit?
- What problems need to be solved?

When: Unlike the “who” and “what”, there is no specific section that can be referenced, to decide “when”, as this decision is based on infinite internal and external factors specific to an individual retailer. The remaining implementation guidance and technical requirements can empower retailers with the knowledge required to decide when is right for them. Key “when” questions include:

- When should transition to 2D begin? (e.g., unlikely to occur during winter holiday periods)
- When will testing, feedback, re-testing, deployment and QA be required to enable the various phases of the 2D implementation project?

6.1.1 Steps for retailer 2D implementation

Retailers have an opportunity to migrate their in-house produced/processed/compiled goods to a single 2D barcode, as they have full control and visibility of 2D capabilities within their store environments. This means that retailers may not need to include dual barcode with both a linear and 2D barcode during the transition period, if all the POS hardware and host systems within the store have 2D capability enabled.

If parts of the store ecosystem are not yet 2D capable, retailers may choose to continue using existing linear barcodes for all in-store processes, as well as own-brand/private label, to minimise impact to label size or format changes to accommodate dual barcoding. This section provides an example of the steps for a retailer 2D implementation with considerations of WHO, WHAT, and

WHEN to trial the implementation of a single 2D barcode on in-store produced stock, before implementing for own-brand/private label.

1. Decide on the locations for the pilot, ideally with a mix of store types (WHAT)
2. Assess and review the current state of equipment and system capabilities (WHAT), and communicate with suppliers and solution providers to enable 2D capability (WHO)
3. Ensure all staff from the chosen pilot locations understand the impact and requirements for the pilot, including support channels (WHO)
4. Decide on the use case to prioritise/benefits to be achieved for a successful pilot. For example, food safety, waste management and/or reduced to clear (WHAT)
5. Decide on which products or product types will be used for the trial, based on the chosen use case (WHAT)
6. Deploy trial, collect results, modify/enhance processes as required based on test results, re-trial, and collect learnings to apply necessary changes for the environment e.g., review verification grades, x-dimensions, scan rates, staff and customer feedback etc.
7. Once the pilot is successful, the changes can be implemented to other parts of the business (WHEN), likely in coordination with solution providers (WHO) to enable capability across the entire retailer ecosystem (WHAT), as well as with suppliers (WHO) to implement 2D on own-brand/private label manufactured stock (WHAT).
 - i. In this example, the retailer can migrate from linear barcode, straight to a single 2D barcode if all parts of their store ecosystem are 2D capable already. If not, dual barcoding is not required as retailer can continue using the existing linear barcode, until such time 2D capability is enabled in the store ecosystem, to minimise impact from label size or format changes to accommodate dual barcoding.
 - ii. Refer to the Application Standards for trade items defined in the GS1 General Specifications.

6.2 Product identification in retail

Globally unique, unambiguous product identification is critical to many retail use cases regardless of the type of barcode. The introduction of 2D barcodes and the ability to encode additional data beyond the product identifier is offering opportunities to improve business processes. This includes potentially leveraging the Global Trade Item Number (GTIN) in place of Restricted Circulation Numbers (RCNs).

6.2.1 Why GTIN is essential for product identification and retail operations

GTINs are essential in retail as they provide a standardised and globally recognised system for product identification, inventory management, point-of-sale (POS) transactions, information accuracy, supply chain visibility and e-commerce operations. GTINs help streamline retail processes, improve accuracy, enhance consumer experience and enable efficient management of product data throughout the retail ecosystem.

- **Product identification:** GTINs provide a globally unique identifier for each product, allowing retailers to accurately identify and differentiate between items in their inventory. This ensures that the correct product is selected and sold to consumer, minimising errors and confusion.
- **Efficient inventory management:** GTINs play a crucial role in inventory management systems. By scanning barcodes encoded with GTINs, retailers can track the movement of products throughout their supply chain, monitor stock levels, and facilitate efficient stock replenishment. GTINs enable retailers to automate processes such as stocktaking, reordering, and tracking product movement, leading to improved efficiency and reduced costs.
- **POS transactions:** GTINs are used at the POS to record and complete a purchase transaction (i.e., go beep at check-out) accurately and quickly. Scanning barcodes encoded with GTINs allows for the automatic retrieval of product information, such as pricing and description, which speeds up the checkout process and minimises pricing errors.

- **Product information and accuracy:** GTINs in barcodes correlate to information held in product databases that contain essential information, including product descriptions, dimensions, weight, manufacturer details, and other attributes. By associating GTINs with accurate product information, retailers can provide customers with detailed and consistent product data, both in-store and online.
- **Supply chain visibility:** GTINs help facilitate supply chain visibility and traceability. By using GTINs throughout the supply chain, retailers can track the movement of products from manufacturers to distribution centres and ultimately to the retail stores. This visibility enables improved supply chain management, accurate demand forecasting, and effective recall management if necessary.
- **E-commerce and marketplace retailing:** In the digital retail environment, GTINs play a critical role in online marketplaces and e-commerce platforms. They ensure accurate product listing and categorisation, help to automate product recommendations, streamline product searches and facilitate interoperability between different systems and retailers.

For further information on the application standards where GTINs are used, please refer to the GS1 General Specifications.

6.2.2 Transition from Restricted Circulation Numbers (RCN) to GTIN

Restricted Circulation Numbers (RCN) are available for special applications in restricted or closed environments, such as use within a specific geographic region or within a company. RCNs are used internally by retailers for the identification of variable measure trade items or own-brand/private label fixed measure trade items that are not defined for open trade. As defined by the GS1 General Specifications, RCNs cannot be encoded with any GS1 Application Identifier. Therefore, it is important for retailers to know that using Restricted Circulation Numbers (RCN) in barcodes with GS1 element string syntax or GS1 Digital Link URI, including in 2D barcodes is not permitted.

It is recommended to migrate from RCNs to GTIN, as part of the 2D implementation journey since the purpose of global migration to 2D barcodes across retail is to enable a connected future for both businesses and consumers alike. This is only possible with a Global Trade Item Number (GTIN), the globally unique identifier for trade items, that can be exchanged internationally and in a fully interoperable manner. As the GTIN is a GS1 identification key, it holds the power for unlocking all types of associated information for brands, retailers and consumers to use.

Migrating from RCN to GTIN enables an expansion of business functionalities and unlocks new opportunities that can use the additional information supporting GTIN. This is especially valuable for fresh foods, as GTIN enables all the same transactional functionalities provided by RCN for internal purposes, such as price, net weight, count or unit of measure. The GTIN can support these processes and unlock further use cases for both fixed and variable measure trade items through the use of supporting data that can significantly improve food safety, provide concise and timely traceability information, increase efficiencies for inventory management and food waste reduction. GTIN can also be used by parallel requirements such as those arising through regulatory needs (e.g., sustainability and ethical accountability).

To facilitate transition from RCN to GTIN and 2D barcode implementation for retail POS, retailers may consider the following information and best practices:

- An RCN is not a GTIN, despite having a similar structure, therefore it cannot be encoded into a GS1 compliant barcode with the GS1 Application Identifier (01). Doing so may cause problems at POS as the system interprets the RCN as a key to lookup pricing info, instead of retrieving detail from the RCN itself.
- During the RCN to GTIN transition period, an RCN and GTIN can be associated within a retail system, using an internal SKU code. A single GTIN with additional data (e.g., net weight) may need to be associated to multiple RCNs. This enables residual stock carrying only a linear barcode encoded with RCN to be processed per current practices, while ensuring new stock can transition to 2D barcodes with a safeguard in case there is a need to roll back deployment due to troubleshooting.
- Retailers can transition directly to a single 2D barcode on trade items produced/processed in store with in-house generated barcodes, if all parts of their store ecosystem are currently 2D capable.

- During the RCN to GTIN transition period, it is possible to dual barcode a trade item with a linear barcode encoded with RCN and a 2D barcode encoded with GTIN and additional attributes such as variable measure data, if not all parts of the retailer ecosystem have 2D capabilities enabled.
 - Alternatively, retailer can continue using existing linear barcodes with RCN, until 2D capability is enabled in the store ecosystem, to minimise impacts to label size or format changes that would be needed to accommodate dual barcoding.
 - Refer to the Application Standards for trade items defined in the GS1 General Specifications.
 - When scanned, retail systems may use the GTIN and attribute data instead of the RCN. If the RCN needs to be used, the POS system can be configured to recognise an RCN (e.g., 13 digits starting with '02' or '2') and retrieve the required pricing and/or variable measure data from the RCN instead of the retailer's system.
 - If dual barcoding with an RCN encoded in a linear barcode, and GTIN in a 2D barcode, POS scanners may be configured to prioritise the 2D barcode, so that the RCN is not captured at the same time as the GTIN and additional data. See Section [7.5.1](#) 2D in retail barcode scanning considerations for more information.
 - If barcoding with a linear barcode encoded with RCN as well as a 2D barcode encoded with GTIN and additional attributes such as variable measure data, the attribute data encoded in both symbols as well as the human readable text, must be an exact match.
 - GS1 Member Organisations (MO) can be consulted for further guidance on how to transition from RCN to GTIN while ensuring local trading requirements can be met.
-  **Note:** There are no GS1 standards for using an RCN and GTIN on the same trade item. There have been no use cases for this application as RCN is intended for use in closed environments only, whereas GTIN is intended for open environments. Prior to the global migration to 2D barcodes, system changes required to enable recognition and use of GTIN as a first step for retailers seeking to transition from RCN to GTIN. Therefore, there was no need to encode both RCN and GTIN in separate barcodes as the systems simply needed to be ready to process GTINs. During the transition period, it is possible for an RCN encoded to a linear barcode and a GTIN encoded to a 2D barcode to co-exist on the same trade item while the retailer works towards migrating from RCN in a linear barcode to GTIN in a 2D barcode.

6.3 Retailer roles in 2D implementation

Brand owners, manufacturers, retailers and solution providers must work closely together to transition to 2D barcodes. It is important to identify the different internal stakeholders that are vital to the planning and deployment of critical business changes to implement 2D barcodes for retail POS.

As a starting point, the table below outlines each of the departments or roles that may be involved in the various phases of implementing 2D barcodes at retail POS. Alongside each role is a description of the role's responsibilities, as department or role titles may differ between regions and organisations. It is recommended for retailers to review both the role and responsibilities together to identify the relevant stakeholders within their own organisation.

For each role, the table outlines their responsibilities for 2D barcode implementation to highlight the actions required for planning and deployment. In some cases, the actions of one role may be dependent on actions required from other retailer roles, therefore these actions require some form of phasing as they are based on additional conditions.

Table 6-1 Retailer roles and responsibilities relevant to 2D

Role type	Role description / responsibilities	2D implementation responsibility	2D implementation dependencies
Category buyers, account managers	<ul style="list-style-type: none"> ■ Contract/service agreement management ■ Liaison between technical teams of trading partners and retailers ■ Works with master data to confirm articles to be set up 	<ul style="list-style-type: none"> ■ Initiates discussions about transitioning to 2D barcodes with suppliers ■ Discusses impacts, benefits and timelines ■ Identifies with suppliers the articles to transition to 2D barcodes ■ Communicates requirements for barcode data and quality, based on mutual agreement ■ Manages commercial impacts e.g., change management 	<ul style="list-style-type: none"> ■ Team that defines barcode quality and the required data needs to be established to set requirements e.g., transition/transformation team ■ Ensures benefits for suppliers are established and clear to mitigate commercial impacts
Supply chain & logistics	<ul style="list-style-type: none"> ■ Handles the processes for managing inbound and outbound goods ■ Optimises supply and dispatch activities to ensure and enable efficiencies for costs, time and competitive market advantages 	<ul style="list-style-type: none"> ■ As 2D implementation focus is on where trade items are scanned at retail POS there is potential impact on online fulfilment centres (rather than store fulfilment). ■ No impact to trade units scanned in general distribution. For trade units scanned across both environments, actions/activities related to retail POS are applicable. ■ If 2D implementation for general distribution is planned, it is recommended to treat as two separate projects (even if implemented at the same time as retail POS). Note that guidance for general distribution is not in scope at present. 	<ul style="list-style-type: none"> ■ Retail POS transition planning and activities ■ Ensure access to visibility of changes at retail POS and establish feedback loop for learnings from retail POS e.g., enabling 2D and additional data capabilities of equipment, timelines, roadmaps, stakeholder communications etc. ■ Depends on retailer's requirements for transition – focus on POS only, or include gen Dist. Can be done independently.
Product development	<ul style="list-style-type: none"> ■ Packaging and artwork development 	<ul style="list-style-type: none"> ■ Plans and develops new packaging artwork to accommodate 2D barcode, human readable text ■ Removal of EAN/UPC for retailer brand articles, once agreed 	<ul style="list-style-type: none"> ■ Mutual agreement and contract management changes confirmed ■ Technical requirements for barcode space allowance are established
Quality assurance/control	<ul style="list-style-type: none"> ■ Ensures quality of products provided by the supplier including packaging and barcode quality issues 	<ul style="list-style-type: none"> ■ Identifies quality issues and communicates with commercial and manufacturers to address ■ Checks barcode quality (can be random), generally done at various points pre-production. Once completed, supplier is approved for production. ■ Identifies and records data quality e.g., instances of wrong data (where other processes are impacted) 	<ul style="list-style-type: none"> ■ Tests sample products content, packaging and 2D barcodes before manufactures starts full production ■ Data types/format etc needs to be defined (by project/ master data/ transformation teams)

Role type	Role description / responsibilities	2D implementation responsibility	2D implementation dependencies
Store and online operations	<ul style="list-style-type: none"> Store operations management and control of retail stores 	<ul style="list-style-type: none"> Ensures implementation of 2D barcodes improves operational process and mitigates possible impacts 	<ul style="list-style-type: none"> Plans for deploying changes required for POS equipment and systems must be established Includes changes to instore or store fulfilment processes
Marketing	<ul style="list-style-type: none"> Manages brand and external communications including public relations (PR) 	<ul style="list-style-type: none"> Awareness May be required for PR management and customer queries during transition period 	<ul style="list-style-type: none"> PR management after migration completed e.g., Food Safety guarantee
Food and product safety	<ul style="list-style-type: none"> Sponsor and supporter 	<ul style="list-style-type: none"> Communicates the importance of 2D barcodes and benefits to senior executives and stakeholders Promotes use of 2D barcode with embedded data e.g., expiry dates 	<ul style="list-style-type: none"> Varies depending on implementation
IT & system administrators	<ul style="list-style-type: none"> Responsible for the changes in systems to encode and use the additional data in 2D barcodes 	<ul style="list-style-type: none"> System changes and configurations Develops and implements the required system changes Maintains the new ecosystem 	<ul style="list-style-type: none"> Varies depending on implementation
Master data	<ul style="list-style-type: none"> Responsible for creating GTINs and setting up data in system 	<ul style="list-style-type: none"> Communicates the right data elements and AIs are established and communicated for encoding into the 2D barcode Gatekeeper/advisor for new AI requests or queries Gatekeeper of barcode data validation & quality 	<ul style="list-style-type: none"> Varies depending on implementation
Innovation	<ul style="list-style-type: none"> Combines core teams e.g. project, transformation, finance, strategy and leadership teams (LT) 	<ul style="list-style-type: none"> Assess different opportunities, ROI for pilots 	<ul style="list-style-type: none"> Varies depending on implementation
Project/transition management	<ul style="list-style-type: none"> Responsible and accountable for change management, timelines etc. 	<ul style="list-style-type: none"> Responsible for defining 2D quality specs and connecting dots between different parties required to enable transition Can be the starting point to identify 2D opportunities 	<ul style="list-style-type: none"> Requires financial/project sign-off prior to major transformation kick-off Needs to be part of strategy for the business
Strategy teams (business analysts)	<ul style="list-style-type: none"> Analyses market trends, identifying business needs/improvements opportunities Looks at more high-level/to the future 	<ul style="list-style-type: none"> Can be the starting point to identify 2D opportunities 	<ul style="list-style-type: none"> Varies depending on implementation
Leadership (CEO/directors etc)	<ul style="list-style-type: none"> Supports new business opportunities Drives prioritisation of various initiatives, based on business needs 	<ul style="list-style-type: none"> Can be the starting point to identify 2D opportunities Critical sponsor of transformation project 	<ul style="list-style-type: none"> Needs to support and understand value of 2D transition Benefits and ROI must be clearly established for buy-in/to confirm support

Role type	Role description / responsibilities	2D implementation responsibility	2D implementation dependencies
Business insights /data analytics team	<ul style="list-style-type: none"> Focuses on internal business trends and addressing business needs/improvements (more focusses on deeper detail – day to day operations) Provides the user interface/solutions for internal functions e.g., dashboard 	<ul style="list-style-type: none"> Varies depending on implementation 	<ul style="list-style-type: none"> Establishing new data/data pool in systems Criteria for analysis
Customer insights	<ul style="list-style-type: none"> Store feedback from customers Loyalty/membership features Customer segmentation/trends Social media analysis 	<ul style="list-style-type: none"> Provides opportunity for customer to feedback on 2D when piloting 	<ul style="list-style-type: none"> Varies depending on implementation

6.4 Retailer ecosystem

Within a retailer’s ecosystem, there are different touchpoints and processes impacted by 2D barcode implementation that need to be considered throughout the planning and transition phases.

It is recommended that retailers identify the areas of their ecosystem that interact with retail POS barcodes, document current as-is processes and identify any existing issues or gaps. Once this exercise is complete, retailers can begin to identify the benefits and drivers of implementing 2D barcodes for each part of their ecosystem to understand what needs to be prioritised to develop a road map for implementation. This information will drive the type of data required to solve an existing issue or achieve a desired benefit, as well as technical requirements.

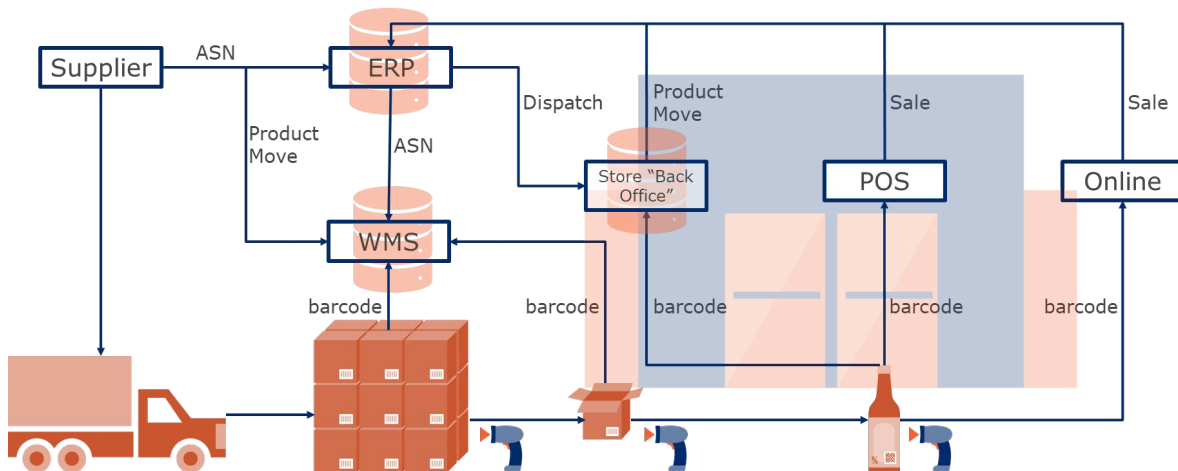

Figure 6-1 Example of a retail ecosystem

The list below provides an example of the ecosystem areas, high-level as-is processes, existing issues and gaps and the different benefits and drivers of implementing 2D. This list is not exhaustive, but intends to demonstrate the considerations and conditional requirements of implementing 2D for retail POS.

Table 6-2 Retailer ecosystem processes, gaps and drivers

Retailer ecosystem area	Current / as-is process	Existing issue / gaps	Benefits/driver to implement 2D
<p>Point-of-sale (POS): includes traditional check-out and self-service check-out</p>	<ul style="list-style-type: none"> ▪ Cashier or customer scans trade item with linear barcode or 2D barcode (including overlays for price reductions); in some regions variable measure fresh food items are also weighed at POS ▪ Only GTIN or RCN captured, processed by POS system to record transaction and update inventory system 	<ul style="list-style-type: none"> ▪ Sales prevention for recalled or expired goods ▪ Automatic price reductions based on conditional requirements e.g., expiration and used by dates, consumer product variant etc. 	<ul style="list-style-type: none"> ▪ Minimise risk/impact to consumer due to purchase/consumption of recalled or expired goods ▪ Improve efficiencies for business processes e.g., time and staff required to remove recalled stock, apply price reduction overlays; reduce human error i.e., missed stock
<p>Online channel POS: includes self-service smart devices used in-store and physical online fulfilment centre</p>	<ul style="list-style-type: none"> ▪ Customer uses Radio-Frequency (RF) device or their own mobile device to self-scan products while shopping ▪ Staff/team uses RF device to scan products for an online order fulfilled in store ▪ Physical fulfilment centre, staff or automation picking and scanning goods to complete an online sales order 	<ul style="list-style-type: none"> ▪ Same as POS ▪ Inability to know/guarantee required lifespan for perishable goods 	<ul style="list-style-type: none"> ▪ Same POS ▪ Validation of perishable goods lifespan
<p>Inventory: Shop floor, stock room or shelf stable areas</p>	<ul style="list-style-type: none"> ▪ Stock is moved from storeroom and placed into shop floor for display and access by customers ▪ Inventory systems will involve scanning such as for stock take, markdowns and inventory adjustments ▪ Stock needs to be rotated to manage expiration dates, markdowns and disposal of expired stock 	<ul style="list-style-type: none"> ▪ Shelf labels including electronic shelf labels with price info need to manually updated/managed ▪ Ability to identify recalled stock and remove from shop floor to prevent sale ▪ Stock rotation is not always certain, very reliant on human visibility and action 	<ul style="list-style-type: none"> ▪ Business efficiencies to prevent/reduce manual labour required to update shelf labels and/or remove impacted stock from display ▪ Stock rotation becomes less reliant on visibility and expiration data may be scanned to assist with staff processes ▪ Implementation of 2D should not impact existing inventory processes

Retailer ecosystem area	Current / as-is process	Existing issue / gaps	Benefits/driver to implement 2D
Inventory: Stock room and Centre store areas for variable measure fresh food and/or staffed counter	<ul style="list-style-type: none"> Staff may prepare or portion food items for customer orders (e.g., deli counter), to be packed and weighed, with on-demand barcode printed for scanning at retail POS and data displayed on POS monitor and customer receipt In some regions, customers may self-select fresh produce from shop floor, weigh their items and print off on-demand barcode label (similar to deli counter). For goods prepared in store, such as bakery goods or cold meats – date and time of production is needed to convey expiry date e.g., for breads time of production or for meat, time of opening equates to time of production 	<ul style="list-style-type: none"> Manual checks are required to determine if stock is close to expiring and/or needs to be removed from sale Inefficient waste management due to reliance on manual checks 	<ul style="list-style-type: none"> Validation of perishable goods lifespan to trigger additional inventory processes
Inventory: Online fulfilment warehouse and store distribution centre	<ul style="list-style-type: none"> Same as store inventory processes Ensure life span of ordered product for customer 	<ul style="list-style-type: none"> Validation of ordered product's life span guarantee 	<ul style="list-style-type: none"> Improved customer confidence with product's life span guarantee
Inventory: 3 rd party distribution centre / facility	<ul style="list-style-type: none"> Supply stock to stores Send (via EDI) additional dispatch information for inventory e.g., expiry dates, batch/lot numbers 	<ul style="list-style-type: none"> EDI information to stores such as expiry dates and batch/lot numbers are not available 	<ul style="list-style-type: none"> Correct item information is recorded in store inventory system and includes expiry dates and batch/lot numbers

6.4.1 Retail POS ecosystem

One of the most critical areas of a retailer's ecosystem is the point-of-sale (POS) area, where trade items are scanned for consumers to complete their purchase and for the retailer to record the transaction. This section outlines the key areas of a retail POS ecosystem that are impacted during the 2D barcode implementation and explains the required considerations to enable capability for 2D barcodes.

Once the required changes have been agreed upon, they can be enacted across systems and processes, to allow for testing phases to begin before final deployment. Consider this part of the 2D implementation journey as laying the foundations. When retailer ecosystems have the capability for 2D barcodes and the ability to recognise the data encoded in 2D barcodes, the additional barcode data can be collected and stored until the retailer is ready to begin using the data and adapting their business process to unlock new use cases and benefits.

 **Note:** Parts of a retailer's POS ecosystem may be found in areas where on-demand labels are generated in-store. For example, variable measure fresh foods may be available for consumers to order from a deli counter or to self-select where a barcode label is generated in-store. Similarly, online fulfilment centres may be considered as part of the retail POS

ecosystem, where trade items are scanned at touchpoints related to fulfilment of consumer orders.

POS system has several components

- Scanner
 - High-speed bi-optic
 - Presentation
 - Handheld scanner
 - & Scale
- Host system
 - POS terminal
 - Display
 - Cash register
 - Card reader



- The scanner must transmit the encoded data of the barcode in a format that the host system can readily accept

Figure 6-2 Example of in-store POS ecosystem

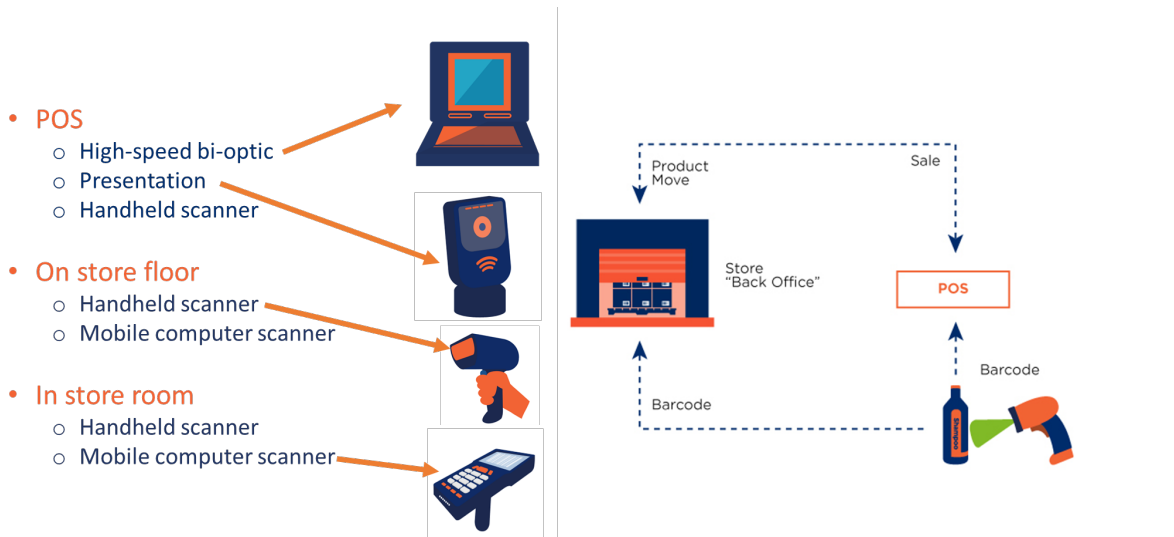

Figure 6-3 Summary of in-store scanner types

- **Scanner:** To upgrade or reconfigure scanners to enable the capabilities for 2D barcodes (e.g., recognition of symbols, syntax and AIs), retailers need to decide which data and/or syntax will be transmitted to the host system by the scanner. To do this, retailers need to engage with solution providers to confirm or request the capability.
 - At minimum, retail barcode systems must be able to process the Global Trade Item Number (GTIN) from GS1 DataMatrix with GS1 element string syntax, QR Code and Data Matrix with GS1 Digital Link URI syntax and all existing linear retail POS barcodes.

- ✔ **Note:** Not all imaging scanners will be capable of the above updates, therefore collaborating with the scanner solution provider will be essential for accepting 2D barcodes at POS.
- **Scales:** Scales are usually connected to the scanner at POS. If not connected to a scanner, scales will usually be connected to the retailer's system to retrieve data for on-demand printing, and for display on a screen for staff or customers.
- **Middleware:** No changes are expected to middleware/shim, unless the scanner or host system is unable to be upgraded or reconfigured.
- **Host system:** Host systems may require upgrades or reconfiguration to enable understanding of all required AIs and/or syntaxes, per decision/choice of what is transmitted from the scanner. Consider the type of data needed for any given process at POS, how and where this data needs to be displayed for staff (e.g., cash register), consumer (e.g., display or receipt) and other places interacting with barcodes (e.g., inventory, reporting).

6.5 Staff and supplier communication and training

With any introduction of new technology or processes, communication and training are required. What type of communication and training is needed and who needs to be involved depends on what changes are taking place. Staff, suppliers, trading partners and solution providers all may need some form of communication or training. Below is an example of the type of communications and training that may be beneficial when implementing 2D barcodes:

Staff

- POS operators / front-of-house (FOH) staff / online fulfilment staff:
 - Communicate changes to check-out processes for POS where an operator may be required to take action.
 - Example: For a consumer safety use case, the expiration date in a 2D barcode can trigger a hard stop at POS to prevent its sale if expired. This requires the POS operator to notify the customer and/or request an alternate trade item to be brought to the cashier, and the subsequent disposal of the expired trade item. The hard stop may be automatically captured and logged to the host system for reporting and may trigger additional inventory processes to check for other impacted stock and remove from sale if necessary.
 - Communicate and provide training for changes to in-store label creation process(es), where additional data needs to be provided by staff for the creation of a 2D barcode for on-demand labels.
 - Example: For a dynamic pricing or waste reduction use case, FOH staff, such as deli operators, may be required to take additional steps to capture the date and time a product was produced or assembled. Doing so can allow the expiration date or date and time to be automatically encoded in a 2D barcode and printed on the trade item's label with human readable text. The POS host system or inventory system is configured so that the expiration information triggers an automatic price mark-down at POS or assists staff with identifying stock which may be close to expiry so that stock can be rotated or moved to promote a price reduction to clear.
- Inventory / fulfilment centre / back-of-house (BOH) staff:
 - Communicate and provide training for changes to processes related to storage, inventory and store fulfilment, where additional data captured from a 2D barcode drives or informs staff activities.
 - Example: For a product traceability and consumer safety use case, capture of batch/lot number or serial number is required when moving stock from storage to shop floor, so that stock can be efficiently located in the event of a targeted recall.

Trading partners

- Stock suppliers (e.g., brand manufacturers, distributors)

- High-level notification to provide advanced notice to suppliers of upcoming discussions for 2D implementation. 1:1 discussion between retailer and each supplier (or grouping of suppliers) to outline requirements for 2D barcodes and determine supplier capabilities, with potential changes to "conditions of supply". Retailer may also discuss requirements for testing/pilots, establishing a feedback loop and samples. A portion of stock or a specific order, may be provided for pilot purposes only, with mutually agreed terms for sampling, troubleshooting, resolution before agreeing on final requirements and any changes to "conditions of supply".
- Solution providers (i.e., software and hardware)
 - Discussions between retailer and their solution provider(s) are needed to outline requirements for 2D barcodes and determine solution's capabilities and/or gaps. Retailer may also discuss requirements for testing/pilots, establishing a feedback loop and samples. These discussions are generally part of a retailer's procurement process for equipment or software, so retailer should ensure the capability for 2D is included within the procurement agreement.
 - Communicate and provide training for changes to processes related to printing, scanning, point-of-sale, inventory and store fulfilment, where additional data captured or 2D barcode drives updates for staff activities.

6.6 What goes into the barcode?

A barcode is simply a carrier for the data needed to enable lookup of associated information within a database. At minimum, all trade items require the Global Trade Item Number (GTIN) encoded in a barcode. Without the GTIN, price lookup and other core retail point-of-sale (POS) functions cannot take place.

Additional data beyond GTIN can be added to barcodes to enable further use cases. For example, a batch/lot number can enable more granular identification of specific production batches. This can facilitate business processes within a retailer environment like a hard stop at check-out to prevent the sale of recalled goods. It is important to consider that additional data may not be available from all suppliers, nor for every product category.

A phased approach to introducing additional data is recommended, to enable a transition to GTIN and additional supporting data between retailers and suppliers. In collaboration with suppliers and internal stakeholders, retailers should consider what data is needed to achieve the business benefits identified as a priority. In other words, retailers should identify the minimum data required to support their use case(s) and consider anything additional as optional for adding into their systems. For example, perishable food items likely benefit from an expiration date to support food waste reduction and inventory management. Batch/lot may be less of a priority, as the data may not be available yet from trading partners, making targeted recalls at check-out based on batch/lot not viable for some time. See Section [6.6.1](#) for examples of common retailer use cases and the data that can help unlock various benefits.

Besides deciding what data needs to be encoded and captured to support the required use case, retailers should understand the two different syntaxes, the GS1 element string and the GS1 Digital Link URI. Both syntaxes can represent the same data but have some differences in terms of capabilities and benefits. For retail implementations of 2D barcodes, systems must be able to interact with both GS1 element string and GS1 Digital Link URI syntax. See Section [6.6.2](#) for best practices to encode data in 2D barcodes, with a retailer's overview of the syntaxes.

6.6.1 Selecting data based on the use case

Additional data beyond the GTIN can be provided by a retail trading partners when supplying stock, as well as by staff for goods processed, produced or compiled internally (e.g., in-store or stock room). This section outlines the most common use cases and benefits which can be achieved with different types of data, where that data may come from and how the data may be accessed or used.

The examples focus on barcodes and labels generated by retail staff for goods produced, processed or compiled within their stores or stock facilities, and demonstrate a single 2D barcode label, as dual barcoding is not required for in-store produced barcodes when 2D capability is not yet enabled

within the store ecosystem. For own brand/private label use cases and barcode label examples, please refer to Brands and Manufacturers' Sections [5.3](#) and [5.6](#) respectively.

The GS1 Application Identifiers (AIs) referenced in the use case Sections 6.6.1.1 to 6.6.1.4, are provided to illustrate how different use cases can be enabled or facilitated through the adoption of AIs. Table [6-3](#) in Section 6.6.1.5 provides an overview of the AIs shown in the examples and demonstrates how various AIs can be applied to more than one of the use cases described. Other AIs or combinations of AIs may also be used in the scenarios. More detailed guidance may be found in the relevant sector specific GS1 implementation guidance. In some use cases, regional regulatory or legal requirements will also need to be taken into consideration.

6.6.1.1 Use case: Waste reduction and improved inventory management (perishable trade items and food safety)

Opportunity overview: When stock has expired it cannot be sold and must be disposed of. At present, without additional barcode data to support GTIN, this is usually a visual check of the store's physical inventory, both in storage and on display - to locate and remove the expired stock from sale, or to move goods with a shorter lifespan for clearance. This can result in store inventory being depleted sooner than expected, as restocking is required to replace expired stock (which may also cause the loss of sales due to being out of stock). When re-stocking, goods also need to be rotated adequately, often through manual checks.

How GS1 standards can help: Additional barcode data such as expiry dates on perishable trade items, can be automatically captured by retailer inventory systems to enable visibility for the lifespan of all perishable trade items in shop floor and storage environments. This information can be used to facilitate food safety and inventory processes to remove expired stock or implement a hard stop at POS, to prevent the sale of expired goods, as well as generate automatic mark-downs at POS to promote clearance of goods close to expiring.

For stock processed, produced or compiled in-store, such as deli meats or baked goods, the legal sell-period and expiration date and time can be driven by the date and time of production, thawing or opening, rather than a supplier defined expiry date.

Barcode and syntax considerations: All Retail POS compliant 2D barcode options and syntaxes are applicable.

For retailer processes where barcodes and labels are generated by staff within the retailer's ecosystem, such as within the deli counter or store bakery, the GS1 element string encoded in a GS1 DataMatrix can be a good starting point for 2D barcode implementation, to easily test and trial new processes involving additional data provided in a 2D barcode. Retailers can focus on getting the data right and adapting in-store/business processes to use the new data, before defining the changes for other areas of the business to use 2D barcodes. Once the retailer is confident with the use of data provided by a GS1 element string within their environments, the transition to GS1 Digital Link URI may be simpler, as the data and labelling space for a 2D barcode is already well established. The only changes needed to switch to or enable capability for GS1 Digital Link URI syntax will be on the software used to encode and decode barcodes.

Please see Section [4.2.1](#) for 2D barcode considerations and Section [4.5](#) for GS1 barcode syntaxes used in retail POS.

GS1 Application Identifier (AI) options:

- (11) Production date
- (15) Best before date
- (16) Sell by date
- (17) Use by or expiry date
- (7003) Expiration date and time
- (7006) First freeze date
- (7007) Harvest date
- (8008) Production date and time

What to link or look up to: Pricing or additional associated data

Summary of key benefits unlocked by 2D:

- Ability for inventory system to record the lifespan of perishable trade items, and automate triggers for inventory processes to locate and remove expired stock from storage and shop floor
- Reduction of waste due to expired stock
- Improved visibility of shelf-life to manage inventory
- Improved inventory and forecasting
- Sale prevention for expired stock
- Automatic price reduction for stock close to expiring

GS1 element string encoded in GS1 DataMatrix, for label applied to consumer trade item packaging:

(01)09521101530001(10)ABC123(8008)2405041126

(01) Global Trade Item Number - 09521101530001

(10) Batch/lot - ABC123

(8008) Date and time of production - 4 May 2024 11:26



Figure 6-4 Example of barcode label generated by retailer for perishable trade items produced in store

6.6.1.2 Use case: Product traceability for consumer safety

Opportunity overview: Consumer safety is paramount and can be compromised when retailer stock is impacted by contamination or sub-standard quality issues within a specific production facility or geographic location. In many cases, a stock recall will be initiated by a supplier to notify retail trading partners and prevent the sale and further movement of impacted trade items. This is of particular importance when related to food safety procedures, as retailers are responsible for preventing the sale of goods identified as being dangerous, to avoid any potential harm to consumers.

However, in some cases, this may not occur within an acceptable time frame for a retailer due to variations in business processes or regional regulatory requirements. In very rare cases, a recall notification may not be initiated by the supplier at all – meaning a retailer may be responsible for initiating investigations to identify impacted stock.

How GS1 standards can help: To facilitate efficient and effective recalls due to contamination in a geographical location, retailer needs to know country of origin (422) and/or country of initial processing (423) for a given batch/lot or instance of a trade item. This data can be provided by a supplier and looked up by a retailer.

For consumer safety issues due to substandard quality of stock from a specific production facility, a batch/lot number (10) is required to initiate a targeted recall; serial numbers (21) can enable

targeted recalls for specific instances within a batch/lot, either held in stock, or sold to a customer; expiry date (17), best before date (15) or production date (11) can also enable the segregation of stock to prevent sale/movement of a partial recall. This data can be encoded in a 2D barcode, for data capture during inventory movements to facilitate stock removal or to prevent its sale directly at POS or captured with sales transactions with potential connections to retailer loyalty cards, to facilitate after-sales notifications for targeted recalls. When batch/lot or serial number is encoded in a 2D barcode it can provide additional data content related to the origin or provenance of the trade item.

Barcode and syntax considerations: All Retail POS compliant 2D barcode options and syntaxes are applicable.

Please see Section [4.2](#) for 2D barcode considerations and Section [4.5](#) for GS1 barcode syntaxes used in retail POS.

GS1 Application Identifier (AI) options:

- (10) Batch/lot number
- (21) Serial number

What to link or look up to: Additional associated data

- (422) Country of origin
- (423) Country of initial processing
- (424) Country of processing

Summary of key benefits unlocked by 2D:

- Ability to identify affected stock and take action within a required timeframe
- Peace of mind for customers and added value for retailer trust
- Enables targeted recall to be initiated by retailer

GS1 Digital Link URI encoded in QR Code for label applied to the consumer trade item processed in store:

HTTPS://EXAMPLE.COM/01/09521101530001/10/ABC123?17=240504&3103=000900

- (01) Global Trade Item Number - 09521101530001
- (10) Batch/lot - ABC123
- (3103) Net weight, kg - 0.900kg
- (17) Expiry date - 04 May 2024



Figure 6-5 Example of barcode label generated by retailer to link or look up traceability information

6.6.1.3 Use case: Transition from RCN to GTIN for migration to open supply chain (variable measure)

Opportunity overview: Variable measure trade items identified with an RCN are prohibited from migrating to 2D barcodes and can impede the implementation of new business processes which rely on encoded data to support GTIN.

How GS1 standards can help: The GTIN is a fundamental GS1 identification key used globally for the unique identification of trade items and can be supported by many different pieces of additional data to improve business efficiencies within a retailer's environment as well as the broader supply chain. Adoption of GTIN also fulfils existing requirements for price look-up of variable measure trade items that were previously identified with RCN embedded with variable measure data. In cases where RCN was embedded with a sell price, retail systems will need to be reconfigured to look-up the price instead.

Barcode and syntax considerations: All Retail POS compliant 2D barcode options and syntaxes are applicable.

The GS1 element string encoded in a GS1 DataMatrix can be a good starting point for 2D barcode implementation, to easily test and trial new processes involving additional data provided in a 2D barcode. Retailers can focus on getting the data right and adapting in-store/business processes to use the new data, before defining the changes for other areas of the business to use 2D barcodes. Once the retailer is confident with the use of data provided by a GS1 element string within their environments, the transition to GS1 Digital Link URI may be simpler, as the data and labelling space for a 2D barcode is already well established. The only changes needed to switch to or enable capability for GS1 Digital Link URI syntax will be on the software used to encode and decode barcodes.

Please see Section [4.2.1](#) for 2D barcode considerations and Section [4.5](#) for GS1 barcode syntaxes used in retail POS.

GS1 Application Identifier (AI) options:

As well as GTIN (01), AIs for price and count or measure (as listed below), to match what is currently provided within the data structure of an RCN:

- Price (392n), (393n), (395n)
- Variable Count (30)
- Measure (31nn), (32nn), (35nn), (36nn)

What to link or look up to: Pricing and additional associated data

Summary of key benefits unlocked by 2D:

- Use of GTIN can enable global data exchange for e-commerce and traceability through the supply-chain
- Ability to use other supporting GTIN data to unlock new use cases, such as automatic mark-downs and improved inventory management of perishable trade items for food safety and waste reduction.

GS1 element string encoded in GS1 DataMatrix for variable measure consumer trade item:

(01)09521101530001(10)ABC123(15)240504(3103)000800(3922)236

(01) Global Trade Item Number - 09521101530001

(10) Batch/lot - ABC123

(15) Best before date - 4 May 2024

(3103) Net weight, kg - 0.800kg

(3922) Amount payable - \$2.36

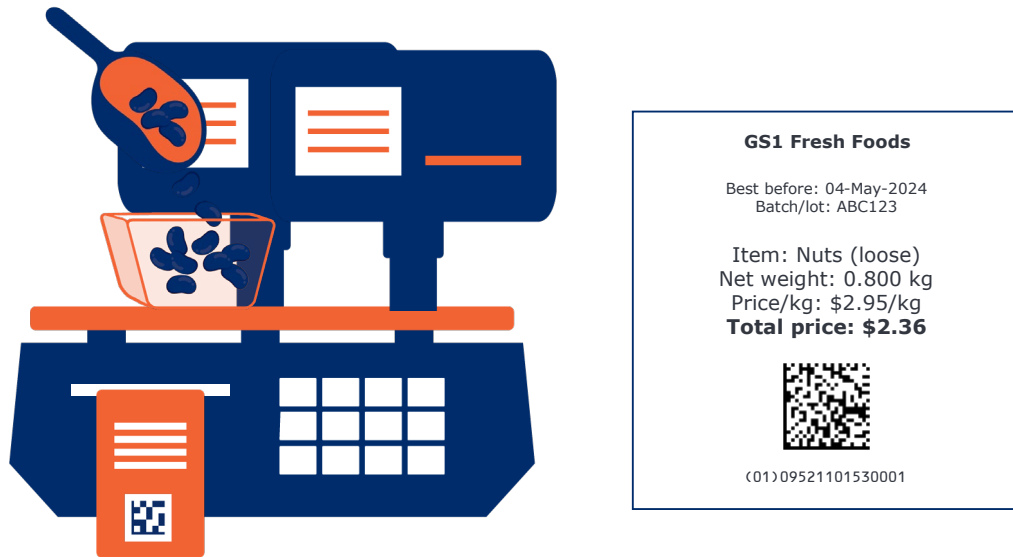

Figure 6-6 Example of barcode label generated by customer for loose fresh produce

6.6.1.4 Use case: Dynamic pricing and automatic mark-downs

Opportunity overview: Inability to apply automatic price reductions or different price points to a single trade item, to improve stock flow, initiate clearance for overstocks, planned promotions or reduced shelf-life.

How GS1 standards can help: Additional data supporting GTIN such as, but not limited to, Consumer Product Variant (CPV) or expiry date, can provide distinction between various iterations of a single trade item, to enable different pricing for the same trade item instore and for online operations. When encoded in a barcode, the GTIN and additional data can be automatically captured in the retailer's systems, to trigger automatic price mark-downs at POS, without the need to manually apply clearance labels for stock (although, staff may still be required to apply updated shelf label or promotional signs). The additional data may also help retailers to guarantee their pricing policy by ensuring pricing is correct in system and at POS, even if physical stock and display labels are incorrect.

Barcode and syntax considerations: All Retail POS compliant 2D barcode options and syntaxes are applicable.

Please see Section [4.2.1](#) for 2D barcode considerations and Section [4.5](#) for GS1 barcode syntaxes used in retail POS

GS1 Application Identifier (AI) options:

- (10) Batch/lot number
- (21) Serial number
- (22) Consumer Product Variant (CPV)
- (15) Best before date
- (16) Sell by date
- (17) Use by or expiry date

What to link or look up to: Pricing and additional associated data

Summary of key benefits unlocked by 2D:

- Enables different price points for the same trade item based on attribute distinction
- Opportunity to automate price mark-downs for clearance or planned promotions
- Improved pricing accuracy and confidence to guarantee retailers pricing policies

- Food safety peace of mind for customers and added value for retailer trust

GS1 Digital Link URI syntax encoded in QR Code for label applied to consumer trade item (original) produced in store:

HTTPS://EXAMPLE.COM/01/09521101530001/10/ABC123?17=270504

(01) Global Trade Item Number - 09521101530001

(10) Batch/lot - ABC123

(17) Expiry date - 4 May 2027



Figure 6-7 Example of barcode labels for dynamic pricing

GS1 Digital Link URI syntax encoded in QR Code for label applied to consumer trade item (variant) produced in store:

HTTPS://EXAMPLE.COM/01/09521101530001/22/321/10/ABC123?17=270504

(01) Global Trade Item Number - 09521101530001

(22) Consumer product variant (CPV) - 321

(10) Batch/lot - ABC123

(17) Expiry date - 4 May 2027



Figure 6-8 Example of barcode labels for dynamic pricing (CPV)

6.6.1.5 Summary of the example use cases that can be unlocked with AIs

Multiple use cases can be unlocked by the same pieces of additional data encoded with the GTIN. Table 6-3 provides a summary of the AIs shown in Section 6.6.1.1 to 6.6.1.4 and demonstrates how various AIs can be applied to more than one of the use cases described. This summary is not intended to be normative and is not an exhaustive list of all available AIs for the use case.

Table 6-3 Summary of AIs shown in examples and the use cases that can be unlocked

GS1 Application Identifiers (AI)	(10) Batch/lot number	(21) Serial number	(22) Consumer product variant	(15) Best before date	(17) Expiry date	(8008) Date and time of production	(3103) Net weight (kg)	(3922) Amount payable
Use Cases								
Waste reduction and improved inventory management (perishable trade items and food safety)	✓	✓		✓	✓	✓		
Product traceability for consumer safety	✓	✓		✓	✓	✓		
Transition from RCN to GTIN for migration to open supply chain (variable measure)							✓	✓
Dynamic pricing and automatic mark-downs	✓		✓	✓	✓	✓	✓	

6.6.2 Best practices for encoding data in 2D barcodes

While it is possible to encode a lot of data in a 2D barcode, retailers should consider whether the data is absolutely necessary for scanning processes to fulfil a business need/use case. If the data can be looked up or linked from another piece of data, it does not need to be encoded in a 2D barcode.

Please see Section [4.6.1](#) for data and format considerations that can optimise the 2D barcodes created in-store and for own-brand/private label trade items.

6.6.2.1 GS1 element string syntax

For retailers, there is less impact to POS systems to transition from EAN/UPC barcode encoded with plain syntax, to a GS1 DataMatrix encoded with GS1 element string, as the capability to read, decode and parse GS1 element string only needs to be enabled for POS scanners to send the required data, in the required syntax to the POS host system. See Section [7.5](#) for more information on scanning considerations and the three different scanning modes implemented with Solution Providers.

If capability for a POS host system to understand and use additional AI data is not yet enabled for a retailer, this will also be required in addition to enabling capability in scanning equipment to recognise GS1 barcode syntaxes. A host system can choose to use only GTIN or GTIN and additional barcode data, based on individual retailer requirements. See Section [7.7](#) for more information on POS host systems.

Note: Retailers need to ensure their decoding and system solutions do not configure any fixed AI sequences, as AIs in a GS1 element string can be encoded, decoded or processed in any order. See Section [4.5](#) for more information on using GS1 element string.

6.6.2.2 GS1 Digital Link URI syntax

Capability for POS scanners to recognise a GS1 Digital Link URI syntax will need to be enabled for the data to be recognised and for the required syntax to be sent to the POS host system. Please see Section [7.5](#) for more information on scanning considerations and the three different scanning modes implemented with Solution Providers.

It's worth noting that a GS1 Digital Link URI syntax does not necessarily need to be encoded in a QR Code to be utilised. A GS1 Digital Link URI can also be constructed by software or a mobile app, when scanning an EAN/UPC barcode or a 2D barcode encoded with a GS1 element string or brand owner's GS1 Digital Link URI, in order to provide retailer driven content for any given trade item in their offering. This practice already occurs today with dedicated retailer mobile apps providing this type of functionality; however, most are likely operating with proprietary solutions rather than the open standards approach offered by the GS1 Digital Link URI syntax.

Please see Section [4.5](#) for more information on using GS1 Digital Link URI syntax.

6.7 Barcode placement and human readable text

For retailers creating barcodes for in-store labelling requirements, such as for variable measure or fresh foods, the general guidance provided in Section [4.1](#) for barcode placement and human readable text is applicable. This Section provides examples of barcode placement and human readable text options, when transitioning directly to a single retail POS compliant 2D barcode.

For own-brand and private label, please see Section [5.6](#) for Brands and Manufacturers' guidance. GS1 standards on 2D barcode placement and human readable text can be found in the GS1 General Specifications.

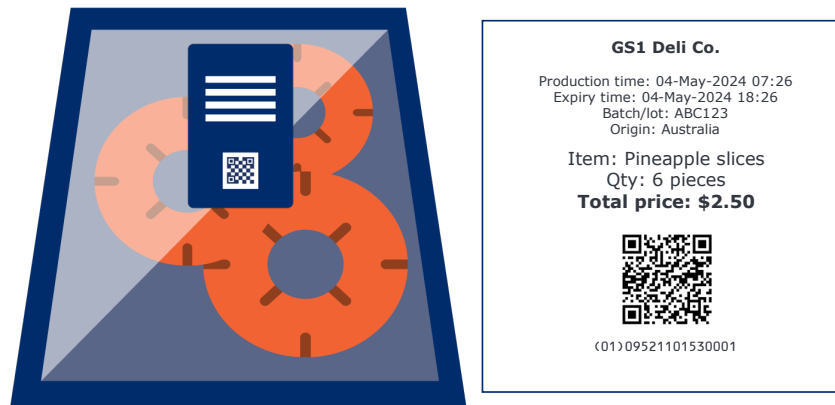

Figure 6-9 Example of single 2D barcode and human readable text placement

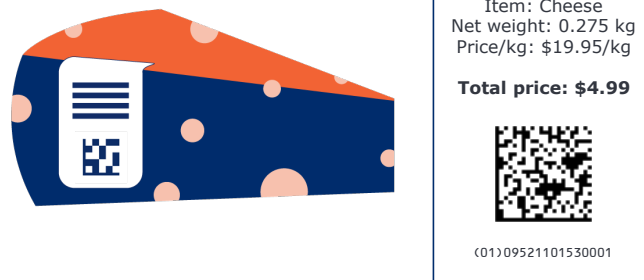

Figure 6-10 Example of single 2D barcode and human readable text placement

6.8 Printing 2D barcodes

This Section is focussed on 2D barcode printing considerations for a retailer's in-store labelling requirements. This includes dynamic printing for trade items produced or prepared within a retailer's environment (e.g., bakery products, hot food etc.) as well as variable measure trade items that require an on-demand barcode printed by a customer or staff, to be scanned at POS (e.g., loose fruit and vegetables, cold meats sliced on demand etc.).

For retailer private label or own-brand printing considerations, please refer to the Brand Manufacturers guidance provided in Section [5.7](#) and [7.4.1](#).

6.8.1 Quality specifications

GS1 symbol specification tables provide the quality specifications, also known as conformance requirements, for barcodes scanned at retail POS, to enable scanning across both optimal and sub-optimal conditions.

Based on the GS1 Symbol Specification tables retailers need to determine what is the optimal 2D barcode size for their own specific environment and product/packaging types. Keeping in mind, the minimum conformance requirements defined by GS1 will be suitable for the most optimal scanning conditions.

As each retailer will have their own scanning conditions and variables to consider within their stores' or facilities' scanning environments, the printing considerations for in-store labelling processes can be a good starting point for retailers to understand 2D requirements to be discussed with their suppliers.

See Section [7.2.1](#) for more information on barcode quality specifications.

6.8.2 Key factors to consider

The following factors need to be considered by retailers, in collaboration with trading partners, when defining new requirements for 2D implementation.

- Printing and production specifications
 - Through extensive collaborative testing the GS1 General Specifications sets the symbol specifications for linear and 2D barcode in the Symbol Specification Tables (SST). For trade items scanned in general retail POS, the X-dimension and quality requirements are defined in Symbol Specification Table 1 addendum 2 for 2D barcodes.

Table 6-4 Symbol specification table 1 addendum 2 for 2D barcodes

Symbol(s) specified	X-dimension mm (inches)			Minimum symbol height for given X mm (inches)			Quiet Zone Surrounding Symbol	Minimum quality specification
	Minimum	Target	Maximum	For minimum X-dimension	For target X-dimension	For maximum X-dimension		
GS1 DataMatrix (ECC 200) (*)	0.396 (0.0150")	0.495 (0.0195")	0.990 (0.0390")	Height is determined by X-dimension and data that is encoded			1X on all four sides	1.5/12/660
Data Matrix (GS1 Digital Link URI) (ECC 200) (*) (**)	0.396 (0.0150")	0.495 (0.0195")	0.990 (0.0390")	Height is determined by X-dimension and data that is encoded			1X on all four sides	1.5/12/660
QR Code (GS1 Digital Link URI) (*) (**)	0.396 (0.0150")	0.495 (0.0195")	0.990 (0.0390")	Height is determined by X-dimension and data that is encoded			4X on all four sides	1.5/12/660

(*) 2D X-dimension - Optical effects in the image capture process require that the Data Matrix and QR Code symbols be printed at 1.5 times the equivalent X-dimension allowed for linear symbols.

(**) GS1 Digital Link URI syntax SHALL use the uncompressed form.

- To achieve a scanning and user reading experience equivalent to that of linear EAN, UPC, and GS1 DataBar family retail barcodes, the X-dimension of 2D barcodes needs to be approximately 50% larger than the linear barcode to ensure consistent readability. This is reflected in the General Specification's SSTs, where 2D barcodes for retail POS are set at 1.5 times the linear X-dimension. Various real-world factors, including product shape (curved, bumpy, etc.), moisture (water droplets, frost, etc.), and contrast (colours within or behind, label sheen, etc.), can influence the scanning experience. Therefore, collaboration among retailers, brands, and solution providers is essential to ensure an optimal scanning experience.
 - The General Specifications outlines the minimum quality grade for the scanning environment. Brands, manufacturers, retailers, and solution providers need to account for process variations and potential quality loss from printing until the final scan at POS.
 - Human readable text such as HRI needs to be part of this consideration. The GS1 General Specification section on Human readable interpretation (HRI) rules speaks to placement and quality of the text. HRI legibility and space for the 14-digit GTIN needs to be accounted for in packaging design. The HRI needs to respect the Quiet Zone of the 2D barcode.
 - **Packaging, labelling material and substrate considerations**
 - Packaging medium/material plays a big role in the scanning performance. For example, a translucent salad bag will need a background behind the barcode to improve the readability of the linear or 2D barcode. Without a highly opaque background, the salad colour showing through the packaging could affect the decoding of the barcode.
 - Packaging or label sheen can also create issues for the scanning equipment as the shiny surface will reflect light back on to the scanner's imager causing the readability issues as seen in Section [7.4.1](#) Figure [7-14](#) Image of 2D barcode on a curve from bi-optic scanner.
 - Packing and label types vary from film packaging on salad bags to labels applied on all different types of products, from flat to uneven or even circular packaging. Considerations need to be taken to ensure the 2D barcode is positioned correctly to minimise part of the barcode being obscured from the view of the scanner. Error correction for 2D barcodes, can assist with the decode (readability) of barcode on odd shaped trade items, but also causes the 2D barcode to grow in size and obscuring more of the barcode.
 - Real estate/space allowance for barcode needs to account for the HRI and the 2D barcode's Quiet Zone.
 - **Store or facility scanning environment**

- Consider position of scanners and lighting/sunlight (time of day) as this can cause inconsistent scanning due to reflectance on mirrors within scanner.
- Store environment conditions such as direct lighting, flashing lights, scanner positioning, air conditioning, debris on scan window and condensation on the products and can affect scanning consistency and contribute to readability issues.
- **Scanning equipment (hardware and software)**
 - Scanner Equipment – flatbed scanners are mostly in use in Retail and the expected performance is a minimum of 40 items per minute.
 - Environmental factors such as lighting and the clarity of the scanning glass play a role in the optimal scanning experience. Often the vertical scanning window of a bi-optic scanner will decode both linear and 2D barcodes more efficiently as there is less light pollution and the surface stays cleaner.

6.8.3 Testing and troubleshooting

This section is focussed on testing and troubleshooting processes for a retailer's in-store barcode production processes e.g., deli goods (for order and pre-packed), fresh food, reduced to clear labels. For guidance on retailer's own brand testing and troubleshooting, please see Section [5.7.2](#) for Brand and Manufacturers information on verification.

When introducing any new or modified barcodes to trade item packaging or labelling, especially when additional barcode data is added to support GTIN, verification of the printed barcode is recommended to ensure it can be scanned in its intended scan environment. For retailers producing barcodes and labels in store, verification of the 2D barcodes, as well as a testing and troubleshooting feedback loop can be very helpful to ensure the newly produced barcode can be scanned, and that the new data can be used by the POS system and/or any related retailer process(es).

When barcode printers and related systems are updated with new software (e.g., firmware updates etc.) or new parts (e.g., print heads, labels etc.), re-verification can ensure that software and hardware updates did not impact the performance and functionality of the 2D barcode. A retailer may also implement a quality assurance (QA) process to record the number of times manual intervention is required at POS per trade item, to better understand cause(s) of any potential repeat issues.

Please see Section [7.6](#) for more information on barcode verification.

6.9 Digital content creation and management

Within the retailer's physical or online store environment, digital content can impact the consumer's experience. At present, consumers can access brand owned digital content by scanning a QR Code on a trade item or its packaging with a mobile device's default camera app. To access retailer owned digital content, consumers can scan an EAN/UPC using a dedicated-retailer's mobile application. Both of these options for a retailer to engage with consumers through retailer driven digital content, already occurs today, however are likely not using GS1 Digital Link. With the use of GS1 Digital Link URIs encoded in QR Codes directly, or GS1 Digital Link URIs constructed with a mobile app when scanning a retail compliant GS1 barcode, retailers have an opportunity to connect with their customers and act more quickly for packaging or product information changes - with no impact to the barcode printed on pack.

For retailers considering the use of GS1 Digital Link, the most important point to remember is that a GS1 Digital Link URI serves as an identifier for the trade item, it is not the Web address of the digital content. For this reason, the creation and management of digital content has no impact or relation to the creation and management of a GS1 Digital Link URI encoded in a barcode on the trade item. The GS1 Digital link URI simply serves as an entry point, to redirect to digital content. That digital content and the redirection can be updated as often as required, without any impact to the barcode applied to the trade item. Best practice is to set-up a basic redirection to the digital content, from the GS1 Digital Link URI. This can be done without a resolver service; however, the

use of a GS1-Conformant resolver enables multiple sources of digital content to be linked to a single GS1 Digital Link URI.

Please Section [4.5](#) for more information and resources on using GS1 Digital Link URI.

7 Implementation guidance for AIDC equipment and software companies

The retail transition to 2D barcodes requires suppliers, manufacturers, solution providers and retailers, with the support of GS1, to work together in order to address concerns, ensure compliance and share learnings.

This section provides guidance specific to solution providers and other technical users implementing 2D barcodes. This content will help users understand business opportunities, changes to existing processes or the introduction of new processes and the requirements that ensure success throughout all phases of the 2D barcode migration.

This includes:

- Solution provider roles and specialisations
- Collaboration with stakeholders
- GS1 compliant retail barcodes
 - Barcode quality
 - Barcode encoded data structures and translations
- Creating/generating 2D barcode considerations
 - Label and barcode design
 - Data content
 - Static and dynamic data
- Printing considerations
- Scanning considerations
- POS host software considerations
- Data sharing considerations

7.1 Solution provider role in 2D implementation

Solution providers play a key role in the transition to 2D barcodes at retail point-of-sale (POS). They are the subject matter experts for barcode creation, printing, scanning, verifying and data sharing. Solution providers collaborate and guide stakeholders on what is possible for the customer to implement a 2D barcode solution.

The 2D barcode in retail journey starts with understanding the use cases the brand, the manufacturer, or the retailer are focusing on. From this starting point the solution provider, in collaboration with the stakeholders, can determine the optimal implementation to achieve the goals. The 2D barcode solution could start in the retail supplier's manufacturing process or in the retailer's ecosystem.

7.1.1 Brand and manufacturer example

A 2D barcode implementation solution is dependent on the way the brand does business. The brand could have a centralised, a decentralised or a combination business model. Centralised production is a business model where all manufacturing processes occur in a single location, often owned and operated by one company. In centralised production the company controls all aspects of manufacturing, from sourcing raw materials to shipping finished products. This approach allows for good quality control and oversight of the entire production process, as well as adaptation to changing market demands. Decentralised production, on the other hand, is a production model

where manufacturing processes occur in multiple locations. This approach is often used when the product line is limited and operations are in close proximity. Decentralisation allows for more flexibility and customisation in production; however, it can also lead to higher costs per unit. The choice between centralised and decentralised production depends on the specific needs of the business.

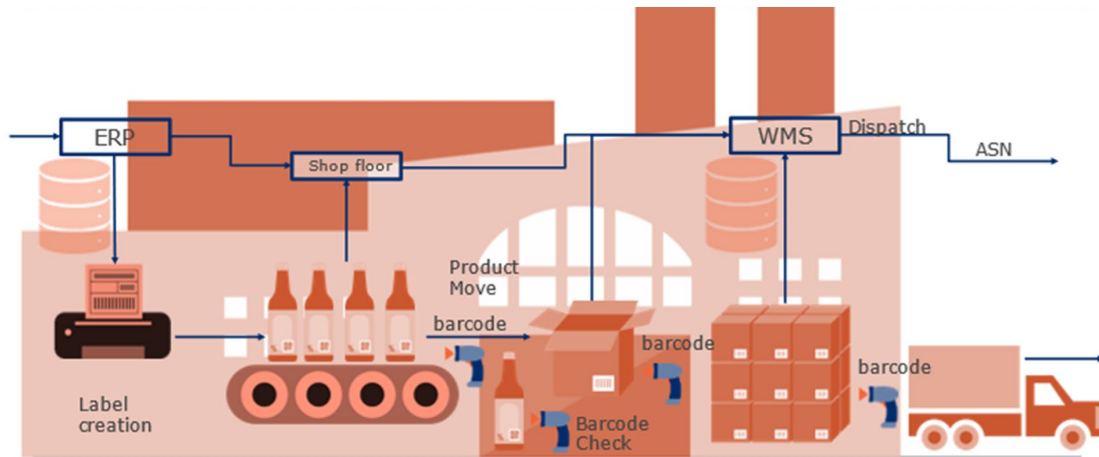

Figure 7-1 Example of a Supplier (manufacturer) ecosystem

Figure 7-1 is an example of a single production line in a centralised model. In this case the production process starts with the enterprise resource planning (ERP) software system that helps organisations automate and manage core business processes for optimal performance. ERP software coordinates the flow of data between a company’s business processes, providing a single source of truth and streamlining operations across the enterprise. ERP software can integrate various functions such as finance, manufacturing, retail, supply chain, human resources and operations. ERP software can also be cloud-based or local-based, depending on the needs of the business model.

The ERP server delivers information for the production run and includes data that may be encoded into the 2D barcode to support:

- Label creation software or printer to produce the barcode
- Scanners to validate that the right data was encoded

The ERP would receive confirmation that the 2D barcode was encoded correctly either directly or through a shop floor solution like a programmable logic controller (PLC) or an industrial software solution. The ERP could then share this information with other databases for traceability, billing and other use cases. The warehouse management system (WMS) would also receive notice from the barcodes to sort, ship and send the advanced shipping notice (ASN) to the receiver.

The label creation phase requires an understanding of the manufacturing processes including:

- **Marking/printing methods** including ink jetting, thermal ink jetting, direct thermal, thermal transfer, LASER, digital (Piezo) and others ...
- What **substrate** will be printed on such as paper, film, plastic, metal, glass and so on....
- **Material handling** constraints like line speed, product pitch, environment (humid/wet, wash down, dusty, hot/cold or other), product suitability and more.
- **Data changes** that are reflected in the 2D encoded data and is it fixed per run, periodic (once per day, on shift change, on lot change, etc.) or every instance.

The scanning phase is used to:

- **Validate** the 2D barcode’s encoded data content and structure (GS1 element string or GS1 Digital Link URI syntaxes)
- **Verify** the print quality and ensure barcode decodability.
- Supply the successful **identification** of the product and data sharing

To make this process work there are multiple stakeholders that a solution provider needs to connect with. See Section [7.1.3](#) Stakeholders’ roles and responsibilities.

7.1.2 Retailer example

The retail environment has many of the same challenges for the solution provider as described in the manufacturing example. The 2D barcode implementation for retailers includes scanning, printing and leveraging the 2D barcode's data to unlock solutions beyond basic inventory and price lookup. Highly integrated retail ecosystems could use distribution centre that would now need to scan 2D barcodes to manage the product movement. These highly integrated stores would not only need to scan the 2D barcode at point-of-sale (POS), but also in the warehouse and on the store shelves. The general term POS includes multiple ways to complete a transaction, such as handheld scanner, presentation scanner, high speed bi-optic and even personal mobile devices.

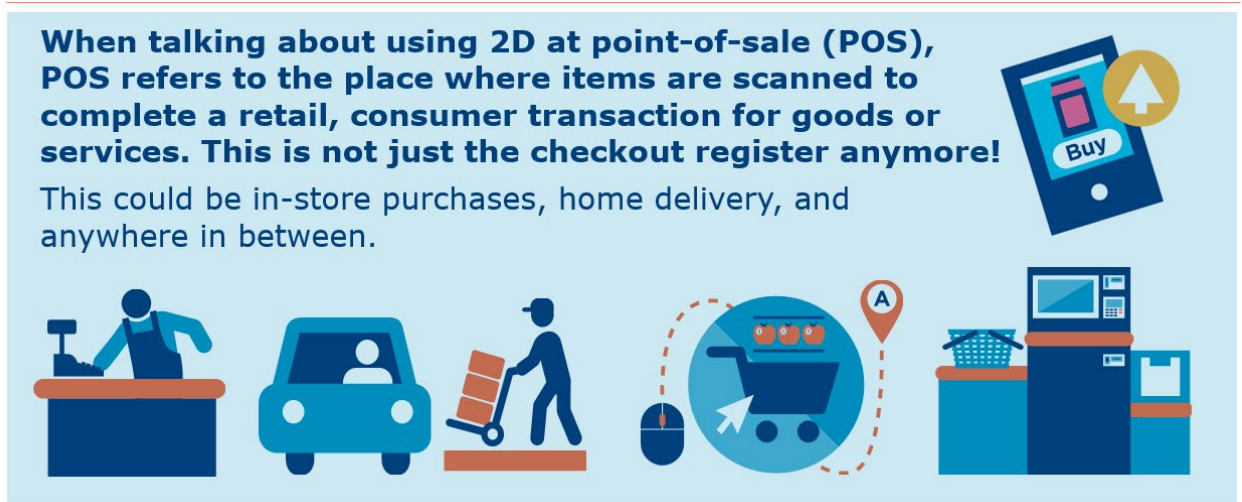

Figure 7-2 Examples of Point-of-sale

There are many types of retail store ecosystems, each with its own characteristics, advantages, and disadvantages. Some of the common types of retail stores are:

- **Grocery supermarkets:** These are stores that sell mainly food and grocery items, along with some household products and personal care items. Figure 7-3 is a representation of one centralised grocery retail ecosystem.
- **Convenience stores:** These are small stores that sell a limited range of everyday items, such as snacks, beverages, cigarettes and lottery tickets.
- **Department stores:** These are stores that sell a wide variety of products across different departments, such as clothing, electronics, home appliances and cosmetics.
- **Specialty stores:** These are stores that sell a specific type of product or service, such as books, jewellery or flowers.
- **Superstores:** These are large stores that sell a wide range of products, often combining the features of supermarkets, department stores and specialty stores.
- **Online/e-commerce stores:** These are virtual stores that sell products or services over the internet, without having a physical location.

These are some of the common types of retail stores, but there are others, such as kiosks, stalls, pop-up stores, and vending machines. Each type of retail store has its own business model, so the solution provider needs to discover the right solution for the specific retailer.

Within a retailer ecosystem, there are a number of touchpoints and processes impacted by 2D barcode implementation that need to be considered throughout the planning and transition phases. Solution providers should work with the retailer to identify areas of the ecosystem that are required to interact with retail POS barcodes, document their current processes and identify any existing issues or gaps.

Figure 7-3 is a representation of a midsize retail store using a centralised model. In this case the retail POS process starts with the enterprise resource planning (ERP) software.

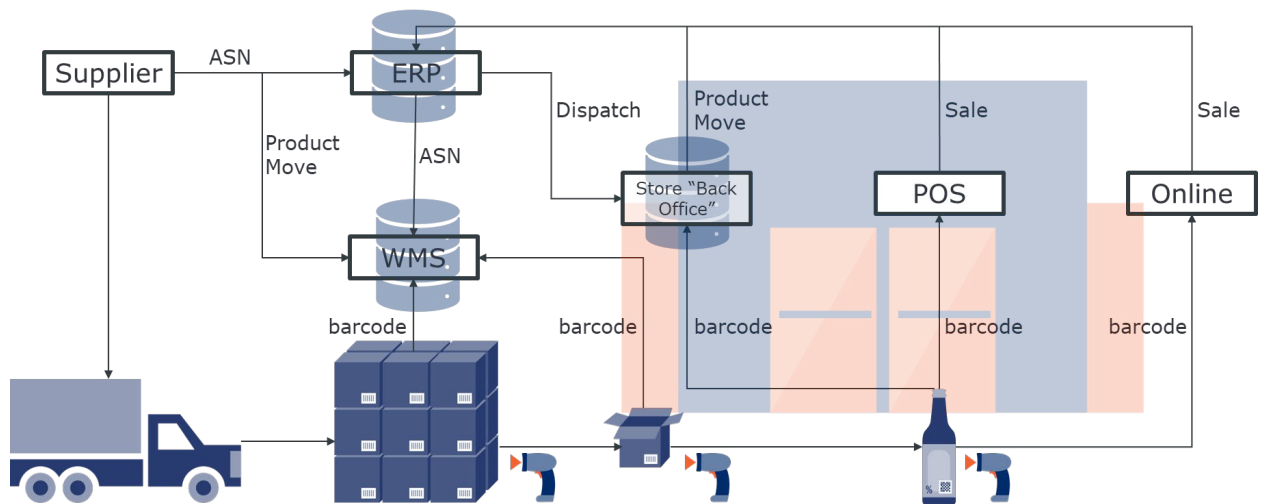

Figure 7-3 Example of a retail ecosystem

The ERP server could deliver information to the warehouse management system (WMS) for products to move to the retail store, the Global Trade Item Number (GTIN) relevant information (e.g., price, price per unit of measure) and much more. The information could be used to encode 2D barcodes in the fresh produce department or to complete POS transactions.

The 2D barcode label creation process would be defined and setup by the retailer's information technology team often in collaboration with solution providers. The retailer could be creating labels with 2D barcodes for prepared meals, baked goods and several other in-store processes. They can also scan 2D barcodes on other products (e.g., brand manufacturers items, private label products). Therefore, many of the label creation and scanning items listed in the manufacturing section may apply.

Elements to consider in the label creation processes could include:

- **Marking/printing methods** are mostly direct thermal, thermal transfer on labels.
- The **substrate** printed on are generally paper and poly labels.
- **Data changes** can come from the retailer's ERP (back office) system or other methods and can include data such as GTIN, price per unit of measure, best before date and others. The 2D barcode data can also come from the weight scale.

The scanning phase is used to:

- Do a price look-up and other use cases for the **2D barcode encoded data**
- **Validate** the 2D barcode's encoded data content and structure (GS1 element string or GS1 Digital Link URI syntaxes)
- **Verify** the print quality and ensure barcode decodability.

While brand manufacturers, retailers and solution providers will work closely together to transition to 2D barcodes, it is important to identify the different internal stakeholders. To make this process work there are multiple stakeholders that a solution provider needs to connect with. The buyer, product identity people, ERP and WMS data people, retail warehouse and store staff, retailer maintenance, IT and other solution providers are just a few connection points. See Section [7.1.3](#) for more details.

7.1.3 Stakeholders' roles and responsibilities

Below are some Retail and Manufacturing stakeholders the Solution Provider should consider when collaborating on the use case or case for 2D barcode implementation.

Note: – Table 7-1 is not in any particular order.

Table 7-1 Stakeholders’ roles and responsibilities

Role type	Role description / responsibilities	2D implementation responsibility	2D implementation dependencies
Leadership CEO/Directors/Senior Leadership/Store Owners	<ul style="list-style-type: none"> Oversee strategy, operations, and finances 	<ul style="list-style-type: none"> Can be the starting point to identify 2D opportunities 	<ul style="list-style-type: none"> Critical sponsor of transformation project, needs to support/understand value of 2D transition
POS Manager	<ul style="list-style-type: none"> Oversee strategies for POS solutions 	<ul style="list-style-type: none"> Ensure right information flows, updated scanners read and parse 2D barcodes 	<ul style="list-style-type: none"> Run the offline validation, co-ordinate store software updates etc
Store Manager Retail or shop-floor associates	<ul style="list-style-type: none"> Store operations management and control of retail stores Day to day scanning of barcodes and providing feedback in terms of scan ability 	<ul style="list-style-type: none"> Ensures implementation of 2D barcodes Improves operational process and mitigates possible impacts 	<ul style="list-style-type: none"> Run day to day operations in a store by evaluating that the solutions of 2D barcodes work and are meeting the Items per minute that is required
Industry Solutions Business Solutions (E.g., Traceability, Sustainability, Circularity, etc)	<ul style="list-style-type: none"> Oversee the planning and execution of business programme or project 	<ul style="list-style-type: none"> Ensures implementation of 2D barcodes based on initiatives given under role type 	<ul style="list-style-type: none"> Analyse if the 2D barcode solution is achieving the necessary goals. For example, if they have the right data for traceability, if the 2D barcodes helping achieve sustainability objectives Ensure the correct sustainable disposal of obsolete equipment
Production managers Line managers	<ul style="list-style-type: none"> Overall efficiency of the production line to meet production goals 	<ul style="list-style-type: none"> Ensure how to be add additional processes (for example, inline dynamic data printing) without causing too much disruption to the production line 	<ul style="list-style-type: none"> Scheduling for updating of processes Ensure availability of associates to be trained for piloting
Supply Chain Managers	<ul style="list-style-type: none"> Work with procurement teams and buyers to source the right products Control manufacturing and delivery processes 	<ul style="list-style-type: none"> Ensure all actors in the supply chain are aware of migration Verify 2D barcodes can be scanned at all points necessary in the supply chain 	<ul style="list-style-type: none"> Liaise with partners to ensure that implementation needs are met in time to support the processes

Role type	Role description / responsibilities	2D implementation responsibility	2D implementation dependencies
Category Managers/Buyers/Purchasers/ Commercial	<ul style="list-style-type: none"> Contract management Liaison between technical teams of trading partners Manage vendors and suppliers Responsible for selection of trading partner 	<ul style="list-style-type: none"> Communicate requirements for barcode data and quality Manage commercial impacts 	<ul style="list-style-type: none"> Initiates the discussions about transitioning to 2D barcodes with suppliers. Discuss impacts, benefits and timelines and ensuring it is clear for all stakeholder to mitigate commercial impacts. Identify with suppliers the articles to transition to 2D barcodes
Maintenance/Facility managers	<ul style="list-style-type: none"> Perform inspection on machine to ensure quality. Ensure maintenance schedule is followed and decisions on repair 	<ul style="list-style-type: none"> Ensure the machinery required are maintained and functioning properly. 	<ul style="list-style-type: none"> Provide inputs in terms of selecting the right machinery for the right operation. For example, keeping the sourcing of printing devices under one manufacturer
Compliance Officer/Quality Officer/controllers	<ul style="list-style-type: none"> Ensures quality of products provided by the supplier including packaging and barcode quality issues 	<ul style="list-style-type: none"> Identify quality issues and communicates with necessary stakeholders internally and externally 	<ul style="list-style-type: none"> Verify the barcode content, structure and quality. For example, ensure the same GTIN is in all GS1 symbologies on the package. Ensure the correct sustainable disposal of obsolete equipment.
Operation Change Manager Project Manager	<ul style="list-style-type: none"> Responsible and accountable for change management, resource usage, timelines etc. Plan the changes focusing on steps, resources and risks anticipation. 	<ul style="list-style-type: none"> Responsible for connecting dots between different parties required to enable transition. Can be the starting point to identify 2D opportunities. Assesses ROI 	<ul style="list-style-type: none"> Require financial/project sign-off prior to major transformation kick-off. Ensure the solution to be part of strategy for the business. Ensure timeline are suitable and met.
Packaging Suppliers	<ul style="list-style-type: none"> Responsible for determining the right type of packaging for the product 	<ul style="list-style-type: none"> Help to select the right substrate to include a 2D barcode 	<ul style="list-style-type: none"> Product development and final printing Connection with product owners For example, Pre-printed or prepare the package for inline printing
Loss prevention specialist/Manager	<ul style="list-style-type: none"> Develop and implement strategies to prevent theft, fraud and stock obsolescence. Ensure compliance with security policies and procedures 	<ul style="list-style-type: none"> Frame new possibilities with stock management techniques. For example UV, Digital signatures in barcodes 	<ul style="list-style-type: none"> Ensure scanning systems and POS systems are scanning the same GTIN

Role type	Role description / responsibilities	2D implementation responsibility	2D implementation dependencies
Product safety	<ul style="list-style-type: none"> Ensures the product produced complies with the applicable requirements and any local/international regulatory compliance 	<ul style="list-style-type: none"> Brings legal requirements into the discussion and alerts to constrains/obstacles and barriers 	<ul style="list-style-type: none"> Ensure the date and the batch/lot information is accurate Retail systems can recognise the product has not reached its 'freshness date'
IT – ERP, Data governance, POS, WMS	<ul style="list-style-type: none"> Oversee technology infrastructure, managing data systems, and ensuring cybersecurity Ensure interoperability amongst the different systems Ensure data is delivered to printing/scanning systems and POS systems in the right way 	<ul style="list-style-type: none"> Connection with input/output hardware Supply the right data Collect and correctly process the additional data 	<ul style="list-style-type: none"> Enable additional data and data structures in a manufacturer or retail environment Critical for piloting data connectivity between IT systems
Webmaster	<ul style="list-style-type: none"> Ensure website services effectiveness 	<ul style="list-style-type: none"> Implementation and alignment for visitors and users' positive experience 	<ul style="list-style-type: none"> Ensure the webpages are up-to date Revise/Redirect websites pages, links and information as necessary
Education & Training Managers	<ul style="list-style-type: none"> Responsible for staff training 	<ul style="list-style-type: none"> Ensure people knowledge of 2D barcodes for daily use 	<ul style="list-style-type: none"> Develop training modules Schedule on-going training initiatives Assess effectiveness of the training
Marketing (Internal/External), Design Managers, Label designers	<ul style="list-style-type: none"> Responsible for label design, changes, 	<ul style="list-style-type: none"> Adjustment of graphical elements in the available space not compromising barcodes performance 	<ul style="list-style-type: none"> Varies depending on implementation
Regulator	<ul style="list-style-type: none"> Ensure the safety, quality, and compliance of products 	<ul style="list-style-type: none"> Varies depending on implementation 	<ul style="list-style-type: none"> Varies depending on implementation
Omnichannel Distribution Managers	<ul style="list-style-type: none"> Oversee the distribution and fulfilment operations across multiple channels Ensure products are delivered to customers in a timely, cost-effective, and seamless manner 	<ul style="list-style-type: none"> Assess the different distribution channels specific needs for 2D barcodes 	<ul style="list-style-type: none"> Follow up with and ensure business partners timely readiness
Product development	<ul style="list-style-type: none"> Packaging and artwork development 	<ul style="list-style-type: none"> Creates new packaging artwork to accommodate 2D Barcode, HRI and non-HRI Removal of EAN/UPC for retailer brand articles 	<ul style="list-style-type: none"> Plan and develop new packaging artwork for the supplier/manufacturer to transition to 2D Barcodes

Role type	Role description / responsibilities	2D implementation responsibility	2D implementation dependencies
Master data	<ul style="list-style-type: none"> Responsible for creating products master data and setting up in the system 	<ul style="list-style-type: none"> Communicate the right data elements and AIs are established and communicated for encoding to 2D 	<ul style="list-style-type: none"> Ensures the right GTIN has the right attributes attached to it

7.2 GS1 compliant retail barcodes

Barcodes are symbols that can be scanned electronically using laser or image-based technology. These symbols are used to encode information such as key identifiers (e.g., for products, shipments, locations, etc.) and additional data (e.g., serial numbers, batch/lot numbers, dates, etc.) using GS1 barcode syntaxes (i.e., plain, GS1 element string and GS1 Digital Link URI). Compliance with GS1’s barcode quality standards and syntax rules ensure that linear and 2D barcodes can be scanned by all supply chain stakeholders, including but not limited to retailers, manufacturers, transport providers, hospitals and consumers.

7.2.1 Barcode Quality

The GS1 General Specifications define a barcode’s X-dimensions (bar width or module size), Quiet Zone requirements, and minimum barcode quality based on where the barcode is being scanned and/or what type of object is being barcoded. See symbol specification addendums for tables 1 and 3 for 2D retail applications in the [GS1 General Specifications](#). GS1 normatively references ISO/IEC barcode test specifications to determine the quality measurements:

- ISO/IEC 15415: Information technology; automatic identification and data capture techniques; bar code print quality test specification; two-dimensional symbols.
- ISO/IEC 15416: Information technology; automatic identification and data capture techniques; bar code print quality test specification; linear symbols.

Each time a linear or 2D barcode is evaluated, a verifier apparatus measures numerous characteristics that are compiled to arrive at an overall score between the lowest score of 0.0 and the highest possible score of 4.0. 2D barcode quality standards use the following compliance factors:

- Decode:** Verification uses the reference decoding algorithm defined by ISO/IEC for decoding the 2D barcode. Valid decoding results in a grade of 4.0. If the barcode cannot be decoded, the resulting grade is 0.0.



Figure 7-4 Example of GS1 DataMatrix

- Symbol contrast:** Symbol contrast is the difference between the darkest and lightest areas of the barcode. This is measured in percentage terms, with the percentages grouped into five different bands – 4,3,2,1, or 0.



Figure 7-5 Example of contrast

- **Axial non-uniformity:** Most 2D barcodes should be square, with evenly spaced elements. Axial non-uniformity is a measure of how 'out of square', a barcode is when checked against its horizontal and vertical axes. This is measured and then graded from 0.0-4.0.



Figure 7-6 Example of Axial non-uniformity

- **Modulation:** A barcode should be evenly dark and light across 2D barcode. Modulation compares the least dark-to-light area of the symbol to the greatest difference between the dark and light elements. This is measured and then graded from 0.0-4.0.



Figure 7-7 Example of Modulation

- **Grid non-uniformity:** Grid non-uniformity measures how the symbol is distorted in terms of how much the implied x and y axes are not at an angle of 90. It is in effect measuring how "twisted" the image is.



Figure 7-8 Examples of grid non-uniformity

- **Unused error correction:** All 2D barcodes include error correction characters that may be used to reconstruct damaged parts of the symbol. A perfect symbol will not require any use of the error-correction characters and will receive a grade of 4.0. The parameter is measured and then graded from 0.0-4.0.

- **Fixed pattern damage:** The fixed patterns of a 2D barcode are used by the scanner to find the barcode. If any of these are damaged the barcode will be more difficult to read, so any damage is measured and graded from 0.0-4.0.

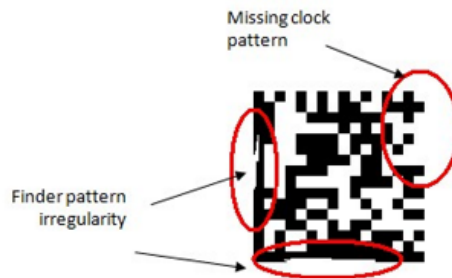

Figure 7-9 Examples of fixed pattern damage

The GS1 Symbol Specification Tables (SST) minimum quality grade for 2D barcodes symbols is shown in this format:

1.5 / 12 / 660

- Where-

- **1.5** is the overall symbol quality grade.
- **12** is the measuring aperture reference number, corresponding to a 0.30 millimetre or 0.012 inch diameter aperture.
- **660** is the peak response light wavelength in nanometres.

7.2.2 Barcode encoded data structures (syntaxes)

GS1 barcodes use one of three syntaxes: plain, GS1 element string and GS1 Digital Link URI. See Section 4.5 for a detailed description of each syntax.

The syntaxes and the data structures that are encoded into barcodes have rules to ensure they can be properly decoded by scanners. The [GS1 General Specifications](#) define the rules for plain and GS1 element string syntaxes, GS1 Application Identifiers (AIs) and the AI associations rules and structures. The [GS1 Digital Link URI Syntax](#) standard defines the rules for the web URI syntax.

Plain syntax is a GS1 data structure containing GS1 identification key with no additional characters or syntactic features. Plain syntax encoded barcodes used in the context of EAN, UPC, and ITF-14 barcodes, refers to the way numeric data is encoded without special characters like FNC1 or additional application identifiers (AI). In plain syntax, the GS1 identification key's numeric data itself represents the information without specific markers for different data elements.

For example, each digit sequence in the plain syntax corresponds directly to the Global Trade Item Number (GTIN) in the EAN-13 barcode, the plain syntax for GTIN-13 (9526064055028) would be encoded as follows:



Figure 7-10 Example in an EAN-13

GS1 element string syntax encoded barcode used in the context of GS1 DataBar family and GS1 DataMatrix barcodes, refers to the way data is encoded with special characters like **FNC1**, group separators or additional GS1 Application Identifiers (AIs). GS1 element string syntax is used for representing one or more data elements, including GS1 identification keys and additional data, used in barcodes. AIs can be encoded in any order and the data structures may have a fixed or a variable

length. GTIN-8, GTIN-12 and GTIN-13 are all encoded in a 14-digit format. This 14-digit format is not the same as a GTIN-14. For efficient encoding, it is recommended that variable data be encoded at the end of the element string to avoid the additional special characters which identify the end of the variable data field, though this is not a requirement for the barcode to read correctly.

For example, a GS1 DataMatrix encoded with (01) GTIN-13 (09504000059118), (10)batch/lot number (7654321D), (17)expiration date (December 31, 2027) and (21)serial number (10987) and the Function Code 1 (FNC1) would be encoded with the following:
FNC1010950400005911817271231107654321D**FNC1**2110987.

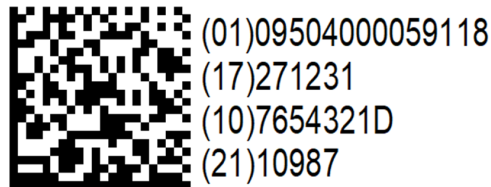

Figure 7-11 Example of a GS1 DataMatrix

✓ Note: **FNC1** is an invisible character designed to identify and separate fields for variable-length application identifiers.

GS1 Digital Link URI syntax encoded barcode used in the context of Data Matrix and QR Codes, refers to the way data is encoded in a web URI structure. A GS1 Digital Link URI syntax is used for representing one or more data elements, including GS1 identification keys and additional data. GS1 Digital Link URI is not normally used as the address of a web page, rather, it should *redirect* to digital information about the identified product.

- **Scheme (Protocol):** The URI begins with a scheme, which specifies the protocol to be used. In GS1 Digital Link, the scheme is typically "https".
- **Domain:** The domain represents the web domain (e.g., a website) hosting the information related to the product.
- **Path:** The path provides a structured way to convey information about the product. It may include elements such as identifiers, attributes, or other parameters. The structure of the path aligns with GS1 Digital Link URI syntax rules.
- **Primary key:** The "id" parameter represents the actual GS1 identification key, such as the GTIN, GRAI, or SSCC.
- **Key qualifier:** This parameter is used to specify the GS1 identification key qualifier. In the case of GTIN, the key qualifiers are consumer product variants (22), batch/lot (10) and serial number (21) indicating more granular versions of the identifier.
- **Additional parameters:** Additional parameters may be included to convey more information, such as expiration date, weight or specific attributes related to the product. GS1 Digital Link URI syntax places GS1 Application Identifiers (AI) into three categories that dictate where they are placed in the data string.

Table 7-2 Examples of Primary Keys, Key qualifier and Additional parameters

Primary Key	Key qualifier	Additional parameter (Data attribute)
(00) Serial Shipping Container Code	(22) Consumer product variant	(17) Expiration date
(01) Global Trade Item Number	(10) Batch/lot number	(243) Packaging component number
(8006) Individual Trade Item Piece	(21) Serial number	(30) Variable count of item
(417) Physical location GLN	(254) GLN extension component	(320n) Net weight, pounds

- !** **Important:** GS1 Digital Link URI syntax order of elements follows a hierarchy, unlike GS1 element strings. For example, the primary key and key qualifier order for GTIN is GTIN > consumer product variant > batch/lot number > serial number.

As an example of using GS1 Digital Link URI syntax see Figure 7-12, which encodes:

<https://example.com/01/09520123456788/10/ABC123/21/456789A?3103=000195&3922=0299&17=201225>

1. **Scheme:** http:// or <https://> (use of HTTPS is more secure and is therefore recommended as best practice)
2. **Host name:** typically, a registered Internet domain name or a subdomain of such a registered domain name (e.g., example.com/)
3. **Path information:**
 - a. **Primary key** such as GTIN, SSCC, GLN, GMN (e.g., [01/09520123456788/](https://example.com/01/09520123456788/))
 - b. **Key qualifiers** such as consumer product variant, batch/lot and serial number (e.g., [10/ABC123/21/456789A/](https://example.com/10/ABC123/21/456789A/))
4. **Query string:** the data attributes such as production date, expiration date, count, price, net weight (e.g., [?3103=000195&3922=0299&17=201225](https://example.com/?3103=000195&3922=0299&17=201225))

- ✓** **Important:** The key qualifiers follow the order of increasing granularity while the additional parameters in the query string can be in any order.



(01)09520123456788

Figure 7-12 Example of a QR Code encoded with GS1 Digital Link URI syntax

Some GS1 Application Identifiers allow special characters like "+", "/", "?" and "&", however these characters have special meanings within Web URIs and serve as structural delimiters e.g., "?" is a query string indicator, "#" is a fragment indicator etc. When these characters are used as literal characters with GS1 Application Identifiers in a GS1 Digital Link URI, they must be represented using percent encoding (see Section 2.1 of RFC 3986 [PercentEncoding]), as defined by the GS1 Digital Link URI standard and listed below:

- Octothorpe = "%23" ; percent-encoding of the # character
- ForwardSlash = "%2F" ; percent-encoding of the / character
- Percent = "%25" ; percent-encoding of the % character
- Ampersand = "%26" ; percent-encoding of the & character
- Plus = "%2B" ; percent-encoding of the + character
- Comma = "%2C" ; percent-encoding of the , character
- Exclamation = "%21" ; percent-encoding of the ! Character
- LeftBracket = "%28" ; percent-encoding of the (character
- RightBracket = "%29" ; percent-encoding of the) character
- Asterisk = "%2A" ; percent-encoding of the * character
- Apostrophe = "%27" ; percent-encoding of the ' character

- Colon = "%3A" ; percent-encoding of the : character
- Semicolon = "%3B" ; percent-encoding of the ; character
- LeftAngleBracket = "%3C" ; percent-encoding of the < character
- Equals = "%3D" ; percent-encoding of the = character
- RightAngleBracket = "%3E" ; percent-encoding of the > character
- QuestionMark = "%3F" ; percent-encoding of the ? Character

For more information see the [GS1 Digital Link URI Standard](#).

7.2.3 Barcodes syntax resources

The GS1 Barcode Syntax Resource is a collection of three assets that provides the tools required by solution providers and users to correctly implement, apply and stay aligned to GS1 standards in a simple and consistent manner. The GS1 Barcode Syntax Resource can be integrated directly into an application's code base or simply used as a reference for transliteration into third-party code as required by the solution build system. The assets can be fully or partially implemented based on the user's requirements and serves as a foundation for building application or user-specific requirements. The assets are as follows:

- **GS1 Barcode Syntax Dictionary** is a simple, open-source text file that contains a list of all currently assigned GS1 Application Identifiers (AIs) and the necessary components for creating a compliant GS1 barcode syntax.
- **GS1 Barcode Syntax Tests** is a set of 'C' language-based source code files that provides instructions to perform a series of analytical actions to check if the data, whether input by keyboard or scanner, is valid against GS1 conformance specifications and rules for the GS1 barcode syntaxes.
- **GS1 Barcode Syntax Engine** is an example of the harmonised framework required to implement the GS1 Barcode Syntax Dictionary and Syntax Tests, to facilitate the detection and conversion of GS1 barcode syntaxes.

The resource offers a baseline for the adoption of the most important, fundamental, GS1 conformance specifications and rules, so that solutions can adopt GS1 standards easily and consistently, without the need to re-invent the wheel. Allowing any application or user specific needs to be built on top of this solid foundation. Figure 7-13 is an example of how that may work in the real world, with the resource being utilised at the point of barcode creation, and again when the barcode is scanned and data is transmitted for use within various applications, such as for POS, for a mobile app or for inventory management purposes.

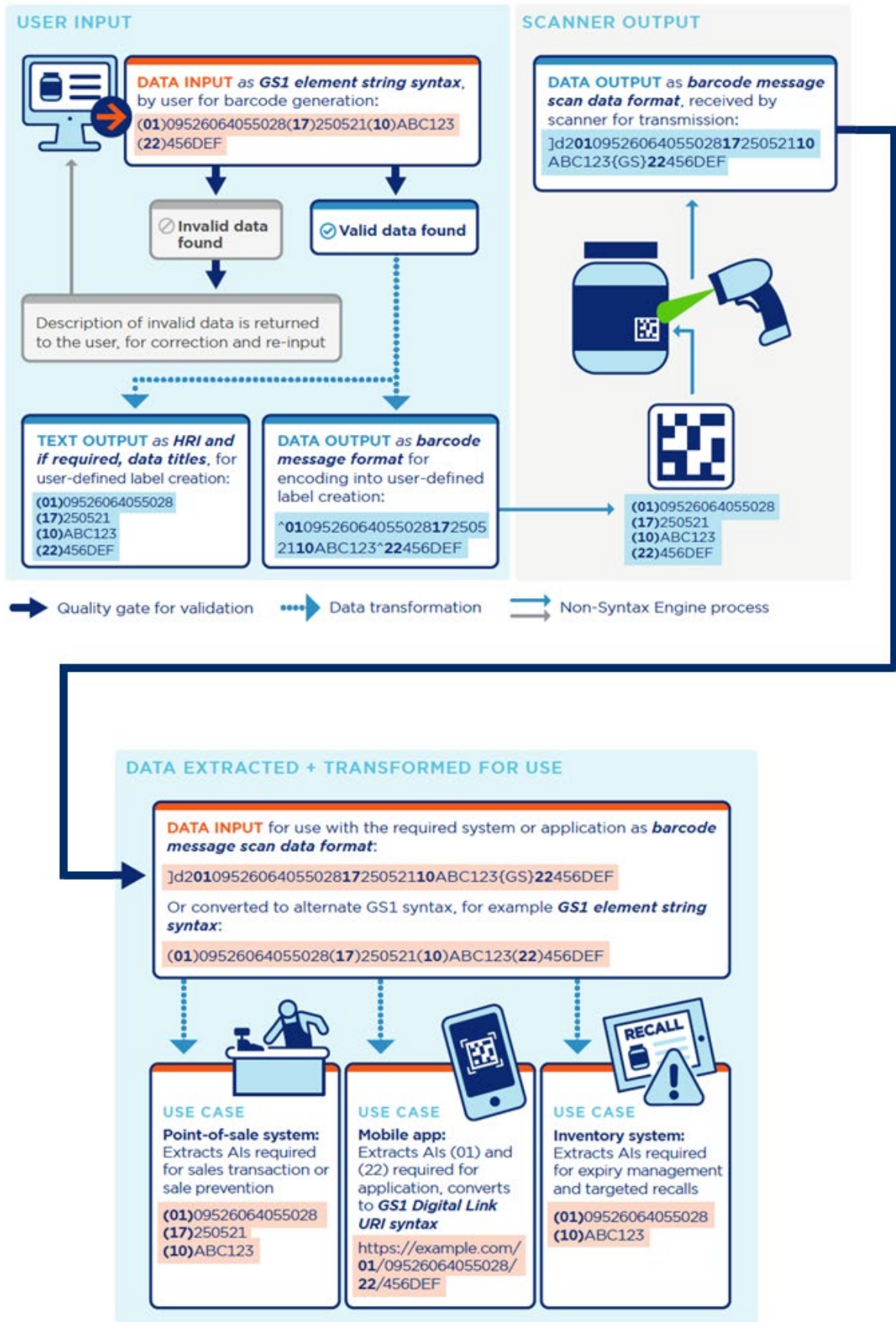

Figure 7-13 Example of a Barcode Syntax Resource solution

The Barcode syntax resources can be found here:

<https://www.gs1.org/standards/gs1-barcodes/gs1-barcode-syntax-resource>

By adopting the GS1 Barcode Syntax Resource, barcode solutions can easily create and process conformant GS1 barcode syntaxes encoded to linear or 2D barcodes used within the GS1 system. This enables industry and the broader GS1 user community to use the full benefits of using any barcode or syntax from the GS1 system and to experience a truly interoperable and standardised implementation of GS1 standards for all their operational data needs, while facilitating the global migration to 2D barcodes, no matter what their chosen solution may be and where they are on their 2D barcode journey.

The Barcode Syntax Resource User Guide can be found here: <https://ref.gs1.org/tools/gs1-barcode-syntax-resource/user-guide/>

7.2.4 Product data for barcode and HRI

Selecting the data to be encoded in a barcode is a crucial step in ensuring the effectiveness of a 2D barcode. 2D barcodes can encode a significant amount of data, but identifying the minimum data set with stakeholders helps keep the 2D barcode size as small as possible and increases the decode efficiency. Here are important things to be aware of when selecting the data to be encoded in a barcode:

- **Data:** Understand the type of data which stakeholders need to encode. Barcodes can represent various types of information, including numeric, alphanumeric and special characters. All retail 2D barcodes in the GS1 system use GS1 Application Identifier (AIs) based element strings. Consider the specific requirements of the application and choose the AIs that best suits the application. For example, a fresh food application may only need GTIN, batch/lot number and expiration date, while a healthcare application will require GTIN, batch/lot number, expiration date and serial number.
- **Length of data:** Variable information such as batch/lot and serial numbers can include up to 20 characters and domain names for GS1 Digital Link URI syntax structures may exceed 20 characters. Determining the minimum characters for batch/lot and serial number or selecting a shorter domain name that will resonate with and give confidence to the user ensures efficiently sized 2D barcodes.

See Section [4.6](#) Optimising 2D barcodes size and data.

- **Human readability:** Evaluate whether the encoded data needs to be human-readable. In some cases, it's essential to have a human-readable representation of the encoded data on the label or product for manual verification. For 2D barcodes intended for retail point-of-sale the 14-digit GTIN is required.

See Section [4.1.3](#) Human readable text and the [GS1 General Specifications](#) Section 4

7.3 2D barcode creation

The linear and 2D barcode can be printed directly onto the product or on an additional label. Both ways need a layout to be created. There are four primary categories for creating 2D barcodes:

- **Open-source code** refers to software whose source code is made available to the public, allowing anyone to view, use, modify and distribute the code.
- A **software development kit (SDK)** is a set of software tools, libraries, documentation and sample codes provided by a software vendor to assist developers in creating applications for a specific software framework, platform, or hardware device. The availability of an SDK simplifies the development process by providing pre-built functionalities, tools, and resources that developers can use. ERP systems often use SDK solutions to ease system integration.
- **Commercial label design software**, is specialised software used for creating and printing labels in various industries. These tools offer advanced features and capabilities for designing labels, barcodes, and RFID (Radio-Frequency Identification) tags. Some common features for commercial label design include:
 - **Label template design:** advanced label design capabilities, allowing users to create complex labels with graphics, text, barcodes, and other elements.

- **Data integration:** integration with databases and business systems enables dynamic data on labels, ensuring accuracy and efficiency.
 - **Compliance:** these tools often comply with industry standards like GS1 and regulations, making them suitable for businesses with specific labelling requirements.
 - **Automation:** solutions support automation to streamline label printing processes and reduce manual effort.
 - **User support:** commercial software typically comes with support services, documentation, and user communities to assist users in optimising their label design and printing workflows.
- **Printer manufacturer software,** are solutions provided by printer manufacturers for the management and control of their printing equipment. These solutions are commonly designed to offer:
 - **Centralised control:** for managing multiple printers from a single interface, enhancing efficiency and reducing errors.
 - **Integration:** these solutions often offer integration capabilities with enterprise systems, databases, and other production-related software for seamless data exchange.
 - **Job management:** job scheduling and management features enable users to optimise printing processes and streamline production workflows.
 - **Compliance:** designed to comply with industry standards and regulations related to coding, marking, and labelling.
 - **Remote monitoring:** allows users to oversee printing processes and diagnose issues, contributing to proactive maintenance and minimised downtime.

7.3.1 2D barcode creation considerations

All four primary categories can be supported by the GS1 Barcode Syntax Resource. Open-source code and SDKs need to be integrated into a larger software solution, while the commercial and printer manufacturers solutions are standalone and can be connected to a brand or a retailer enterprise solution as described in Section [7.1](#) brand manufacturer and retailer examples.

It is essential to work with all stakeholders to select the right retail 2D barcode and create the most efficient solution to achieve their use cases. Optimising the data to minimise the 2D barcode's size ensures subsequent printing and scanning success. When designing or creating 2D barcodes for retail refer to the standards and rules in the [GS1 General Specifications](#).

7.4 Printing

Once the 2D barcode's data and encoding have been optimised, the next step is printing the barcode. The chosen method of printing will depend on the size of the barcode, the speed of manufacturing, the type of substrate and whether the data encoded is static or dynamic. Some of the other factors in choosing the printing technology include the ingress protection (IP) rating, the total cost of ownership and any environmental impacts.

The major printers used in manufacturing include:

- **Continuous Ink Jet (CIJ):** CIJ is a non-contact printing technology that uses a continuous stream of ink droplets. The ink is expelled through a small nozzle and then charged and deflected by electrodes to create characters on a substrate. CIJ is commonly used for high-speed printing on various materials, including packaging. Most CIJ application involve printing dates or other traceability information, but 2D barcodes are well within this type of printer's capability.
- **Thermal Ink Jet (TIJ):** TIJ is a non-contact printing technology that uses tiny resistors to heat and vaporise ink, creating small bubbles. The expansion of these bubbles propels ink droplets onto the substrate, forming characters or barcodes. TIJ is often used in desktop printers and smaller-scale printing applications like 2D barcodes. One of the largest TIJ applications is GS1 DataMatrix printed in healthcare applications.
- **Thermal transfer and direct thermal**

- **Thermal Transfer:** A printing method where a thermal print head applies heat to a ribbon, transferring ink onto the substrate, usually label or film. It is commonly used for high-quality and durable printing, such as 2D barcodes on labels.
- **Direct Thermal:** This method uses heat-sensitive paper or label stock. When the thermal print head applies heat, it activates the chemicals in the paper, creating characters or barcodes. It is often used for shorter life span labelling applications.

Within these thermal printer methods, there are three main categories:

- **Thermal Transfer Overlay (TTO)** is a variation of thermal transfer printing that is commonly used in the packaging industry. It involves printing variable data, such as expiration dates or batch/lot numbers, onto flexible packaging materials.
- **Desktop label printers** are compact printers designed for small to medium printing volumes. They are commonly used in office settings, retailer or smaller production environments for tasks such as printing labels, barcodes, and shipping tags.
- **Print and apply systems** are automated solutions that print labels on-demand and apply them to products or packages. These systems are often used in industrial settings for labelling products with variable information.
- **Laser:** Light amplification by stimulated emission of radiation (LASER) technology is used in printers to produce high-quality 2D barcodes. In the context of industrial printing, lasers are often used for marking and coding on various materials. With laser printing, marking quality is dependent on the substrate reaction to the laser wavelength. There are multiple wavelengths and three laser processes:
 - **Ablation** removes layers of material (ink) exposing lower surfaces and can generate 2D barcodes scannable by the majority of imaging scanners.
 - **Engraving** melts (plastics) or fractures (glass) creating grooves or pockets in the substrate. The 2D barcode created by engraving requires specialised lighting and vision systems.
 - **Thermo-chemical** uses the reaction of a material within the substrate (e.g., mica) or added to the surface (e.g., water-based finishing). The contrast is often capable of being scanned by the majority of imaging scanners.
- **Drop on demand (DOD):** DOD is a category of inkjet printing technology where ink drops are precisely ejected from a print head onto the substrate. This method allows for precise control over droplet placement and is often used in industrial and commercial printing. There are two major types of DOD printers.
 - **Valve jet** is a specific type of DOD technology where ink droplets are ejected through a valve mechanism. Most large valve jet printers are not appropriate for retail 2D printing applications, but smaller valve jet methods like micro-electro-mechanical systems (MEMS) valves are known for their high-speed and high-resolution capabilities that can generate quality 2D barcodes.
 - **Piezo** DOD technology generates ink droplets by changing the shape of piezoelectric crystals within the print head. Piezo technology is known for its versatility and compatibility with a wide range of inks.
- **Commercial printing presses** are used across a wide range of industries for producing printed materials such as packaging, labels, newspapers, magazines, books, promotional materials, and more. Various printing technologies used in commercial printing operations include gravure, flexography and offset printing processes.
 - **Rotary Gravure** printing is a high-speed, high-quality printing process that uses engraved cylinders to transfer ink onto a substrate, often used for long print runs of magazines, catalogues, packaging materials, and decorative print.
 - **Flexography, or flexo printing,** is a widely used printing process that utilises flexible relief plates to transfer ink onto a variety of substrates. It is commonly used for packaging materials, labels, newspapers, and corrugated cardboard.
 - **Offset printing,** also known as lithography, involves transferring ink from a plate onto a rubber blanket and then onto the printing surface. It is suitable for a wide range of substrates and is commonly used for books, magazines, brochures, and packaging.

They play a crucial role in the production of printed media and are essential for meeting the printing needs of businesses, publishers, advertisers, and consumers. The process of creating transfer plates means the 2D barcode data will be static for the production run unless a digital printer is added to the printing press processes.

- **Digital printing (Piezo)** involves the precise control of ink droplets through the deformation of piezoelectric crystals. It is commonly used in various printing applications, including graphics, textiles, packaging and industrial labelling. Digital printing allows for dynamic data printing and customisation. Inline production applications are emerging but require very good material and product handling. Offline preprinted application labels and product packaging are the most common solution for adding 2D barcodes.
- **Emerging printing technologies** have been resetting the upper limit for printing 2D barcodes. This next generation of printers includes binary array lasers, super piezo inkjet, high-speed piezo and thermal reactive ink coatings that enable current laser to achieve new top speeds. These next generation printers are achieving 120 meters per minute, exceeding the needs of most high-volume production lines.

7.4.1 2D barcode printing considerations

Each printing technology has advantages and limitations based on requirements such as maximum height, print resolution, speed of print, substrate to be printed on, the printing environment and the expected 2D barcode durability. Appendix [8.1](#) provides details for the above printing technologies.

The printing technology meeting the retail 2D barcode size and production speed requirements does not mean the application will be successful. A 2D barcode printing solution also requires repeatable and stable product and material handling. The relative position of the 2D barcode module is important to ensure scanning is successful. Quality 2D barcodes are produced when the product's printing surface is not moving perpendicular to the printing head at a measured velocity. Other key factors include the opacity of the ink, the colour of the background and where the printing surface is flat or has a sheen.

The placement is dependent on if the 2D barcode is intended for retail point-of-sale scanning or only consumer engagement (see Section [5.6.2](#)). It is important to avoid areas with potential interference from graphics, folds or other packaging elements that would compromise the required 2D barcode Quiet Zones.

It is key to ensure sufficient contrast between the 2D barcode and the background colour of the packaging. High contrast enhances readability and scanning accuracy. Surfaces with a sheen can reflect light and affect what the scanner can decode, so it is recommended that they be avoided. Figure 7-14 shows the camera image from the two mirrors of a bi-optic scanner. Note the lower reflection has a white line caused by label sheen and the specular reflection of the scanner's light source.



Figure 7-14 Image of 2D barcode on a curve from bioptic scanner

By carefully addressing all considerations, the effectiveness of the 2D barcode can be enhanced on the product packaging, ensuring reliable scanning and accurate data capture throughout the product lifecycle.

7.5 Scanning

Imaging scanners are engineered to accurately decode 2D barcodes, tailoring their performance to meet diverse application requirements. These specifications encompass factors such as the module size of the 2D barcode, the scan rate, the context in which the barcode is being decoded—whether for consumer engagement, point-of-sale transactions, production line operations, or general distribution. The environmental conditions, including lighting, dust levels, and moisture presence are also important design considerations. The [GS1 General Specifications](#) define a barcode's X-dimensions (bar width or module size), Quiet Zone requirements, and minimum barcode quality based on where the barcode is being scanned and/or what type of object is being barcoded. See symbol specification addendums for tables 1 and 3 for 2D retail applications.

Major imaging scanner types include:

- **Bi-optic scanners** are a type of barcode scanner equipped with two sets of scanning components. These scanners often have two imagers (i.e., cameras) and multiple mirrors, allowing them to read barcodes from different angles. Bi-optic scanners are commonly used in high-volume retail environments for fast and efficient checkout processes.
- **Presentation scanners** are designed for hands-free operation, typically used in retail or point-of-sale settings. They are often mounted or placed on a counter and the user presents the barcode to the scanner. These scanners quickly capture barcodes, making them suitable for fast-paced point-of-sale scenarios.
- **Handheld scanners** are portable devices held by the user for scanning barcodes. They are versatile and can be used in various industries, including retail, logistics and healthcare.
- **Mobile computer scanners** are portable devices, often integrated with mobile computers or smartphones. These scanners are ideal for applications where mobility is crucial, such as inventory management, field service or asset tracking. They may use built-in cameras for 2D barcode scanning.

- **Fixed scanners** are stationary devices installed along a production line for automated barcode scanning. They are commonly used in manufacturing, logistics, and distribution environments to efficiently scan products as they move along the production line. These scanners can be integrated into conveyor systems.
- **Mobile device scanners** refer to barcode scanning functionality integrated into smartphones or tablets. Modern smartphones come equipped with built-in cameras capable of scanning barcodes. Apps and software use the camera to capture and decode barcode information. This approach is common for inventory management and consumer engagement applications.

7.5.1 2D in retail barcode scanning considerations

To make the transition to accepting 2D barcodes at point-of-sale (POS), scanner software will need to be updated:

5. To process trade items that may have multiple barcodes encoded with GS1 data structures and identification keys, for example a GS1 DataMatrix and an EAN-13 can be on the same trade item and will have the same GTIN.
6. To identify GS1 DataMatrix barcodes, Data Matrix encoded with GS1 Digital Link URI syntax and QR Code encoded with GS1 Digital Link URI syntax
7. To convert GS1 Digital Link URI syntax to GS1 element string syntax

✓ **Note:** Not all imaging scanners will be capable of the above updates, therefore collaborating with the scanner solution provider will be essential for accepting 2D barcodes at POS.

For the 2D barcode Ambition 2027, retail POS needs to be able to identify, decode, “beep” once and transmit one GTIN from any GS1 compliant general retail linear and 2D barcode:

- EAN/UPC family of barcodes (plain syntax) is standard
- GS1 DataBar retail family (GS1 element string syntax) is standard and may need to be enabled
- GS1 DataMatrix (GS1 element string syntax) is standard and may need to be enabled
- Data Matrix (GS1 Digital Link URI syntax) will require a software update to identify the syntax and convert to GS1 element string
- QR Code (GS1 Digital Link URI syntax) will require a software update to identify the syntax and convert to GS1 element string

To unlock new retail use cases beyond just GTIN, imaging scanners need additional software modes.

When there is more than one barcode with GTIN on trade items, it is essential that the POS systems will ensure:

- The system SHALL only process one set of the desired data in the final transaction.
- Scanning systems SHOULD only produce one acknowledgement (e.g., beep) when multiple barcodes encoded with the same GTIN are scanned from the trade item.

✓ **Important:** If the points above are not implemented, unintended POS transactions may occur.

7.5.2 2D in Retail scanning modes

Industry has agreed on three primary software modes that should be implemented in scanners:

- **Mode 1**

All POS systems can process GTIN from EAN/UPC family of barcodes (plain syntax). Many POS systems can process the GTIN and some additional data (e.g., lot/batch, expiration date) from GS1 DataBar retail family and GS1 DataMatrix that use GS1 element string syntax. Updated POS

systems can process the GTIN from Data Matrix with GS1 Digital Link URI syntax and QR Code with GS1 Digital URI syntax.

Once the first GTIN is identified in a linear or 2D barcode, irrespective of the presence of multiple GS1-compliant retail barcodes on-pack, the scanner promptly process and transmits the GTIN with a single audible (e.g., beep) or visual signal, and awaits subsequent product.

 **Note:** This minimum requirement for the Ambition 2027 is software Mode 1

■ **Mode 2**

Prioritise GS1 compliant general retail 2D barcodes, decode, “beep” once and transmits GTIN and any additional data (e.g., lot/batch number, expiration date) in the common format of GS1 element string syntax and, if one cannot be found, transmit data from the linear barcode. Any data that the system is not able to store or use can be dropped.



	 9 506000 134352	<p>QR Code encoded data https://id.dalgiardino.com/01/09506000134352/10/ABC?17=231231 Independent of the direction of travel the scanner transmits: 010950600013435210ABC^17231231</p>
---	--	--

Figure 7-15 Example of Mode 2

In this example, the “^” replaces the unprintable hex 1D (Group Separator) character

■ **Mode 3**

Identify, decode, and transmit all GS1 compliant general retail barcodes (linear or 2D) on a product, while generating an **8-digit label identification** to associate multiple barcodes with the same trade item. Upon capturing the first GTIN from either a linear or 2D barcode, the scanner promptly provides a single audible (e.g., beep) or visual signal. The scanner will generate an **8-digit label identification** in a common format header of the barcode’s Plain & GS1 element string syntax.



	 9 506000 134352	<p>QR Code encoded data https://id.dalgiardino.com/01/09506000134352/10/ABC?17=231231 Independent of the direction of travel the scanner transmits: 12345678~010950600013435210ABC^17231231 12345678~9506000134352</p>
---	--	---

Figure 7-16 Example of Mode 3

In this example, the “^” replaces the unprintable hex 1D (Group Separator) character and the “~” is not transmitted but shows the end of the label identification.

 **Note:** All scanner software solution can benefit by leveraging [GS1’s Barcode Syntax Resources](#).

As noted above, when there is more than one barcode with GTIN on trade items, it is essential that the POS systems will ensure:

- The system SHALL only process one set of the desired data in the final transaction.
- Scanning systems SHOULD only produce one acknowledgement (e.g., beep) when multiple barcodes are scanned from the same trade item.

 **Important:** If the points above are not implemented, unintended POS transactions may occur.

7.5.3 2D in Retail scanners with limited capabilities

In some cases when the imaging scanner is not capable of being updated with the above modes the POS solution provider may implement a middleware solution, also known as a shim library, that transparently intercepts and enables solutions to achieve the identify, decode, “beep” once and transmit one GTIN from any GS1 compliant general retail linear and 2D barcode.

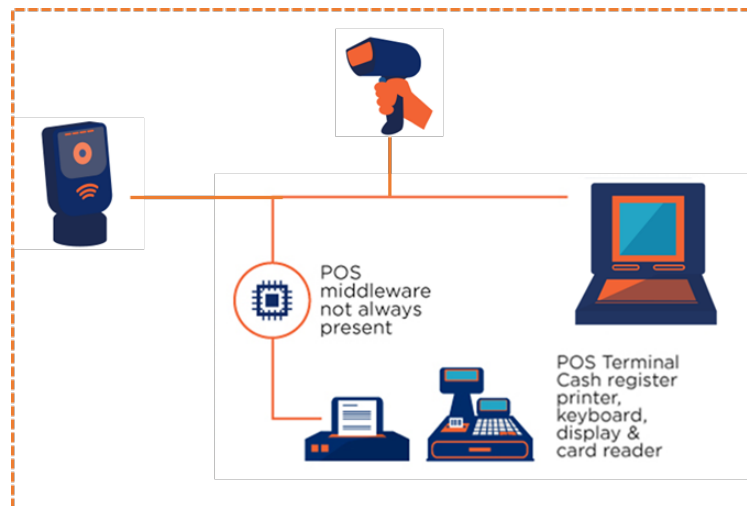

Figure 7-17 POS system with middleware feature

7.6 Verification

A barcode verifier is a specialised device designed to assess and grade the quality of printed barcodes. Unlike barcode scanners that are focused on reading barcodes for data capture, verifiers are specifically used to ensure that a printed barcode meets industry standards, and the barcode is encoded with a compliant data structure.

Verification scanners are generally used as offline auditing devices and have portable or desktop models to test for all barcode quality requirements. Inline fixed verification scanners are becoming more popular and allow manufacturing to track the quality of every barcode in real time, however they may not test all quality requirements.

Common features of barcode verification scanners include:

- **Verification grades** or quality assessment of the barcode based on industry standards, such as the ISO (International Organisation for Standardisation) specifications. Verification scanners analyse various aspects of the printed barcode, including line contrast, edge contrast, symbol contrast, and quiet zones. These factors contribute to the overall print quality and readability of the barcode. See Section [7.2](#) for barcode quality parameters used in verification processes.
- **Compliance checking** of the printed barcode’s compliance with specific symbology standards, encoding rules and dimensions.
- **Data accuracy** of the encoded data within the barcode. This ensures that the information encoded in the barcode matches the intended data structure.
- **Reporting and documentation** about the quality of the scanned barcode. This information is valuable for quality control, compliance and troubleshooting purposes.

7.7 Point-of-sale (POS) host systems

A POS host solution is a comprehensive, hardware and software solution that facilitates the processing of sales transactions, inventory management and related retail operations. It serves as a central hub for managing various aspects of the retail business, providing tools to enhance customer

service, optimise inventory and improve overall operational efficiency. It is commonly used in brick-and-mortar stores as described in the retail example in Section [7.1.2](#), but it can also integrate with online sales channels for omnichannel retail experiences.

POS host systems generally facilitate:

- **Processing of sales transactions**, including the calculation of variable weight items, monitoring of expiry dates, sales totals, taxes, and discounts.
- **Inventory management** in real-time, enabling businesses to optimise stock levels and prevent stockouts.
- **Product (trade item) database** with detailed information about items, including prices, descriptions, and stock levels.
- **Integration with hardware** components such as barcode scanners, weight scales, receipt printers, and cash drawers.
- **Payment processing** for various payment methods, including credit/debit cards, cash, and mobile payments.
- **Reporting and analytics** for sales, inventory turnover, and other key metrics to make informed decisions.

POS host systems are often tailored to the retailers needs to realise other business use cases such as managing operations across different stores.

7.7.1 2D in retail barcode POS host system considerations

There are thousands of POS host software solutions in the global marketplace. Adding a new syntax such as the GS1 Digital link URI to them presents a challenge. To alleviate this challenge, it is recommended that POS scanners convert the GS1 Digital Link URI syntax to the well-established GS1 element string syntax.

POS host systems will need software updates to enable and manage advanced retailer use cases. The three possible scanning modes detailed in Section [7.5.2](#) offer levels of functionality for the POS host system:

- Mode 1 allows the POS host system to still manage the solution with only GTIN.
- Mode 2 requires the POS host system to be configured to manage more granular data such as expiry date and weight.
- Mode 3 requires the POS host system to be configured to manage more granular data such as expiry date and weight, and also label identification numbers.

A best practice recommendation is to update any POS host system with all possible GS1 Application Identifiers (AI) relating to retail GTIN applications when a retailer is looking to unlock use cases beyond price lookup.

8 Appendix

8.1 Printers

Printing technologies with significant market share and production history are in focus. The following serves as a general overview and guidance, but it is essential to verify individual process parameters in all cases.

8.1.1 Continuous Ink Jet (CIJ)

Overview

Continuous Inkjet (CIJ) is a non-contact printing technology that employs a consistent flow of ink droplets. The ink maintains a specific viscosity, circulating continuously within the system. Ink pressure is precisely calibrated to achieve a manageable jet speed, measured in droplets per

second. Within the printer, the ink is directed into a chamber housing a vibrating resonator and an orifice that expels droplets. This ink contains salt components capable of carrying an electric charge. Through a controlled process, certain ink droplets are charged, with the magnitude of the charge determining the degree of deflection by electrodes. Uncharged droplets are efficiently recirculated back into the printer via a recuperation tube. The combined effect of deflected droplets and the perpendicular motion of the printhead or substrate collaboratively generates characters or 2D barcodes.

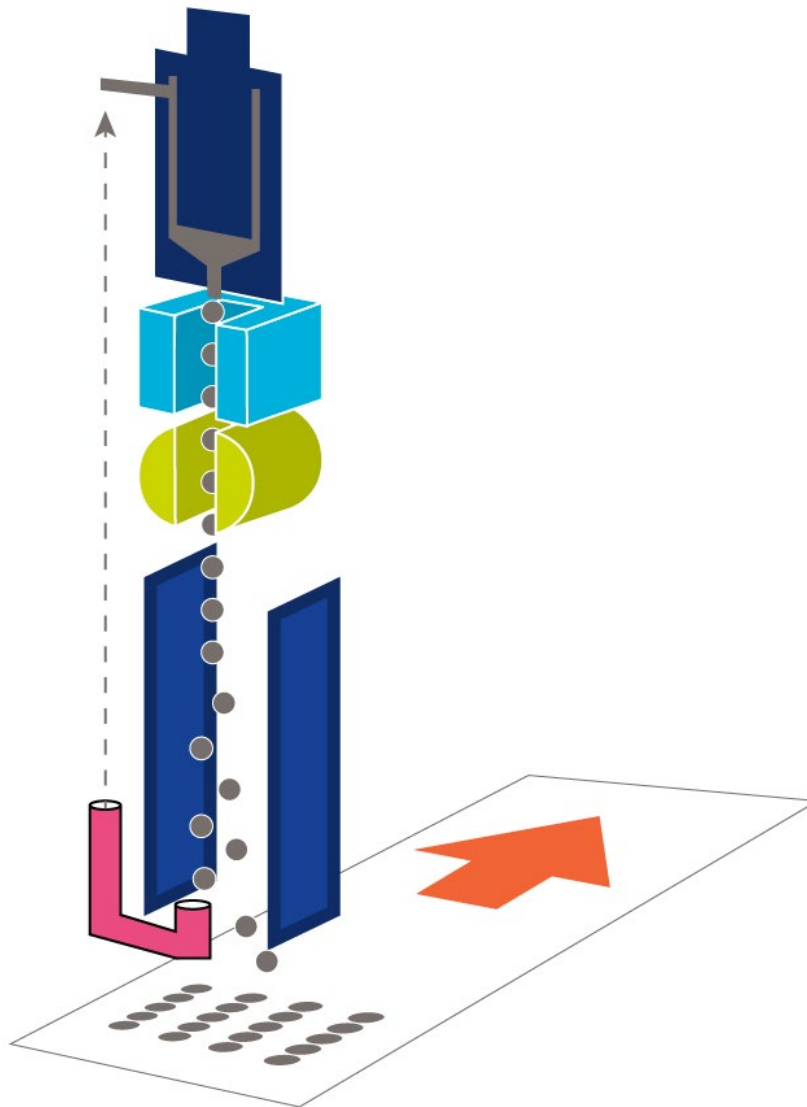

Figure 8-1 Example of a CIJ print head

Production:

- Inline production processes across various substrates.

Ink types:

- Solvent base, which that flashes off
- UV-curable, designed to achieve substate bonding or fastness

Technical overview (How It Prints):

Print resolution is 60-180 dpi, determined by the drop size.

Speed and quality for 2D barcodes:

- 45 m/min
- Mid-quality of 2-3 per ISO quality Specification (Section [7.2](#)) for 2D barcodes
- CIJ will produce 2D barcodes that can be scanned in the retail environment

Maximum 2D height:

- 24-32 dots
- Suitable for primary and direct part marking across various sectors

Use cases:

- Suitable for primary packaging and direct part marking across various sectors

Environment:

- Will function in environments up to IP66 protection
- Suitable for dusty or washdown areas
- IP rating can vary and is dependent on printer design (see Section [8.2](#) for IP ratings)

Maximum 2D barcode size:

- 24- & 32-dot high printheads
- Bi-jet and quad-jet configurations stack multiple printhead jets that are capable of higher dot configurations
- As data content can quickly exceed printer 2D size capability, data optimisation is key
- Best practice is to use 4 dots fewer than maximum (i.e., causing the maximum height to be 20 and 28 dots), to avoid print quality problems associated with the most deflected droplets.
- Using 4 dots per module can improve scannability, but greatly reduces the maximum data.
- The 2D finder pattern can be difficult to manage as the most deflected droplets may not repeatably land aligned to the prior droplet or dot.

X-dimension:

- Determined by drop size, which in turn is determined by jet orifice diameter and ink migration on the substrate
- Smaller drop size may not meet the minimum requirements defined by the GS1 General Specifications

Substrates:

- There's no "ideal" CIJ ink that works on every substrate, in terms of ink adhesion and fastness (i.e., ability to maintain opacity or colour)
- A given ink's dry time needs to be understood
- Testing on the packaging or trade item is important

Material/product handling (product moving):

- The CIJ printhead can be **10-30 mm** from the printed surface, depending on the application
- Distance from printhead to printed surface should not vary by more than +/- 2 mm
- Printhead stand should be permanently mounted
- Printhead holder should be 'keyed' or have locating features to ensure repeatable, precise placement, independent of operator
- Printed surface must be perpendicular to the printhead's jet
- Print speed should be monitored via an encoder that is in a closed loop with the printer

- Dot (module) interspatial uniformity is determined by printhead distance, as well as by the moving speed of the printed surface

Material/product handling (printhead moving):

- **As above (product moving)**, but printhead stand is not permanently mounted
- Printing should be avoided during acceleration of the printhead, to ensure dot (module) interspatial uniformity

Environmental considerations:

- Inks use solvents to maintain ink viscosity and expedite drying
- Special attention must be given to the use of gloves, ventilation and air circulation.
- Regarding waste controls, locally applicable VOC (volatile organic compound) regulations need to be considered
- Ongoing consumption of electricity and additive, because printer needs to run without interruption to maintain ink viscosity.

Quality control:

- Inline vision systems are used to validate 2D data content or verify specific print quality characteristics
- Can be augmented with periodic, offline verification (i.e., spot checks) of random samples
- 2D error correction (ECC) helps maintain acceptable read rates.

Challenges/Limitations of CIJ

- Maximum print speed limit is determined by 2D barcode height (i.e., number of dots high)
- The 2D barcode print height is limited due the maximum dots allowed by the printhead design and for improved dot placement quality may be further limited at the maximum jet deflection.
- In practice, maximum speed is ~ 45 m/min for Mid-Quality (grade 2-3) barcodes.
- Print resolution is 60-180 dpi and should not be a limitation for 2D barcodes in retail.
- Printer and printhead jet control and maintenance are important, as misaligned printheads and dirty jets will not print reliably

Advantages of CIJ

- Limited capital expenditure (CAPEX)
- Low total cost of ownership (TCO)
- Versatility and modular designs
- Limited integration effort
- Latest innovations with respect to VOC (volatile organic compound) regulations
 - e.g., new MEK (methyl-ethyl-ketone)-free inks significantly reduce VOC emissions
- Adhesion solutions for the majority of substrates in use.

8.1.2 Thermal Ink Jet (TIJ)

Overview

Thermal Inkjet (TIJ) is a printing technology that employs tiny thermistors (thermal resistors) to heat and vaporise ink, creating small bubbles. TIJ printers generally utilise an ink cartridge that contains a lightly pressurised bladder of ink. The ink is forced into tiny chambers which contain resistors. Each chamber has a nozzle opening through which to project ink. When a particular nozzle needs to produce a droplet, an electric current is passed through the corresponding resistor. This rapid electrical heating causes the ink near the resistor to vaporise, forming a small bubble. The expansion of these bubbles propels ink droplets onto the substrate, forming characters or 2D

barcodes. This TIJ technology is well established and has been used in home inkjet printers and is a major solution for healthcare's GS1 DataMatrix printing requirements.

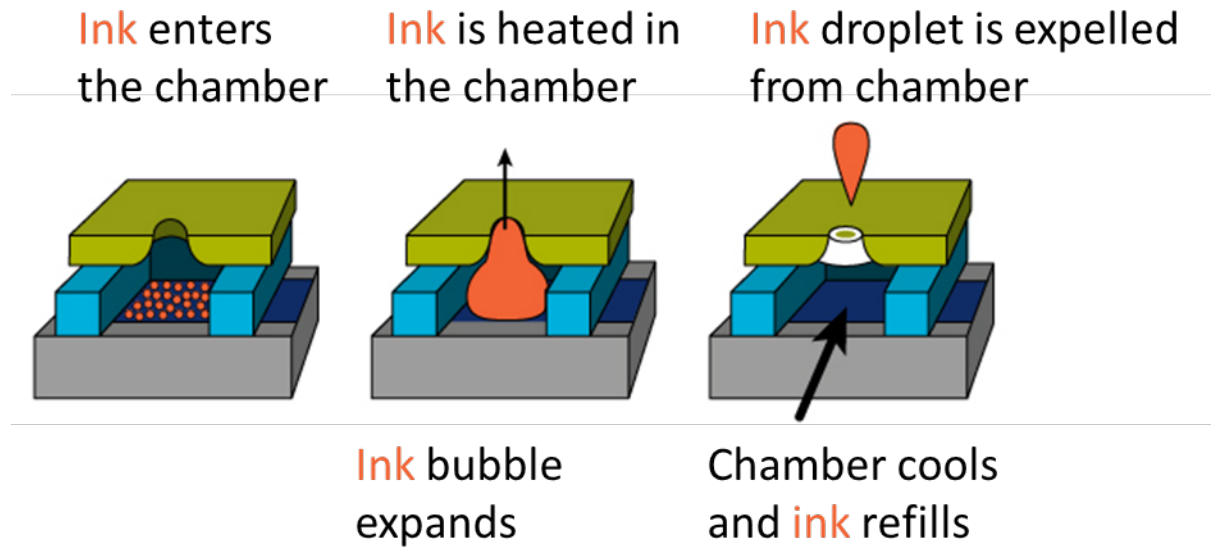

Figure 8-2 Example of thermal Inkjet chamber and process

Production:

- Utilised in inline production applications with flat surfaces (e.g., cartons), because the ink droplets can only travel a small distance

Ink types:

- Aqueous (water-based) inks are used on porous substrates
- Solvent and UV-curable inks are used on coated or plastic substrates

Technical overview (How It Prints):

3 available print resolutions:

- 300 dpi
- 600 dpi
- 1200 dpi

Speed and quality for 2D barcodes:

- Maximum speed 60 m/min
- High-quality grade 3-4 per ISO quality Specification (Section [7.2](#)) for 2D barcodes.

Maximum 2D barcode height:

- 12.7 mm per printhead (cartridge)

Use cases:

- Suitable for flat surfaces, because the ink droplet can only travel a short distance
- Uses across various sectors, but most commonly found in healthcare and flexible film applications

Environment:

- Can function in environments up to IP65 with special protection
- Generally used in IP40 environments, suitable for low-dust and dry areas
- See Section [8.2](#) for IP ratings

Maximum 2D barcode size:

- Printheads are stacked to extend maximum height
- Individual standard printhead height is 12.7 mm (1/2 inch)
- Newer height designs include 22 and 25.4mm
- Because a 2D barcode's data content can exceed individual printhead size capability, optimisation of data content is key.

X-dimension:

- Due to the high printhead resolution (300 dpi), the GS1 General Specifications' 2D barcode X-dimensions are comfortably achievable

Substrates:

- There's no "ideal" TIJ ink that works on every substrate
- The 3 ink types can adhere to most substrate
- Testing is necessary to ensure print requirements are achieved
- Ink adhesion, fastness (i.e., ability to maintain opacity or colour) and dry time need to be understood, based on substrate and ink design

Material/product handling (product moving):

- TIJ printheads should be **3-5 mm** from the printed surface
- Distance from printhead to printed surface should not vary by more than +/- 2 mm
- Printhead stand should be permanently mounted
- Printhead holder should be 'keyed' or have locating features to ensure repeatable, precise placement, independent of operator
- Printed surface must be perpendicular to the printhead's jet
- Print speed should be monitored via an encoder that is in a closed loop with the printer
- Dot (module) interspatial uniformity is determined by printhead distance, as well as by the moving speed of the printed surface

Material/product handling (printhead moving):

- **As above (product moving)**, but printhead stand is not permanently mounted
- Printing should be avoided during acceleration of the printhead, as well as printhead movement near the maximum velocity, to ensure dot (module) interspatial uniformity

Environmental considerations:

- TIJ ink uses additives (aqueous and other solvents) to maintain ink viscosity and expedite drying
- Gloves should be used when handling printheads.
- Regarding waste controls, disposal handling of TIJ ink cartridges needs to be considered, as these are not recyclable

Quality control:

- Inline vision systems are used to validate 2D data content or verify specific print quality characteristics
- Can be augmented with periodic, offline verification (i.e., spot checks) of random samples.
- Printhead cleaning and wipe procedure need to be followed to avoid print degradation.

Challenges/Limitations of TIJ

- Maximum print speed is determined by the jetting capability of the printhead
- In practice, maximum speed is ~ 60 m/min for High Quality (grade 3-4) barcodes.
- Print resolutions are either 300, 600 or 1200 dpi. This is not a limitation for 2D barcodes.

- Printer and printhead jet control and maintenance are important, as printhead jet clogging or malfunction ('jet out') can be caused by dirt or dried ink.
- The path of small 6 picolitre ink drops can be unintentionally deviated by air currents (e.g., due to nearby fans or air conditioning ducts) or static electricity.
- Care needs to be taken to avoid ink smearing due to unintentional contact with the printed surface before the printed ink has dried.
- Variable dry times need to be taken into consideration to ensure that wet ink does not come into contact with another surface
- Stacking printhead for higher 2D barcode can be challenging, and care must be taken to ensure the printing offset is perfect.
- Re-filling should be avoided as the printhead wears over time.

Advantages of TIJ

- Limited capital expenditure (CAPEX) for high-resolution print
- Low total cost of ownership (TCO).
- Versatility and modular designs
- Limited integration effort due to the small form factor of TIJ printheads.
- TIJ ink cartridges are easy to change and use low-to-no VOCs (volatile organic compounds).

8.1.3 Drop on Demand (DoD)

Overview

There are two major DoD printer technologies piezo based and valve jet, both are non-contacting designs as the printhead does not touch the substrate.

A Piezo Drop on Demand (DoD) printer is a type of inkjet printer that uses piezoelectric technology to precisely control the ejection of ink droplets from the printhead. The printhead of a Piezo DoD printer contains piezoelectric chambers (actuators). Piezoelectric material experiences mechanical deformation when subjected to an electric field; this is used to generate pressure pulses, which eject ink through a nozzle. This process is precisely controlled, allowing the formation of ink droplets with high accuracy.

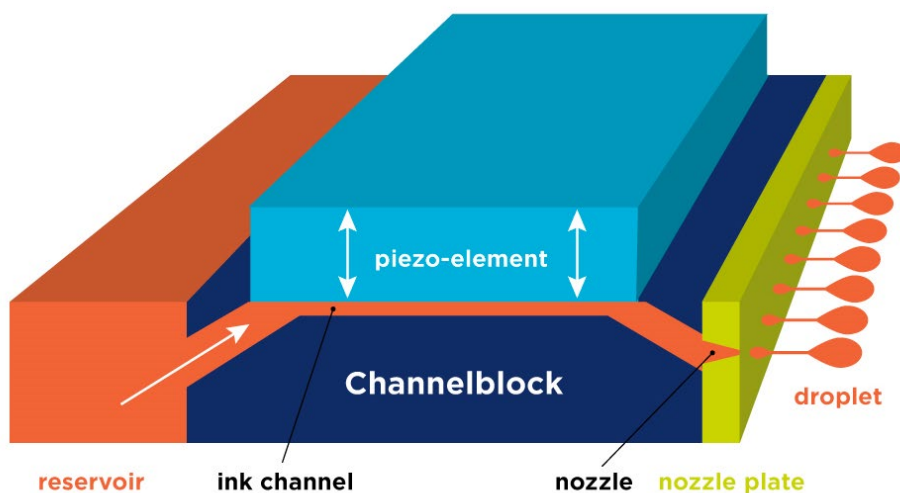

Figure 8-3 Example of piezo chambers

Valve jet technology is primarily used in large character and are low resolution applications. The technology can print 2D barcodes, but the low resolution limits its use in retail applications.

Production:

- Inline production applications with flat surfaces such as cartons.

Ink types:

- Aqueous
- Oil
- Hotmelt (wax-based)
- Solvent
- UV-curable

Technical overview (How It Prints):

3 available print resolutions:

- 150 dpi
- 300 dpi
- 1200 dpi

Speed and quality for 2D barcodes:

- Maximum speed 60-120 m/min
- High-quality grade (3-4) per ISO quality Specification (see Section [7.2](#)) for 2D codes.

Maximum 2D barcode height:

- Maximum matrix height ranging from 35 mm, 50 mm, 72 mm and 144mm
- Suitable for retail and other sectors

Substrates and use cases:

- There's no "ideal" DoD ink that works on every substrate
- The 5 ink types can adhere to most substrates
- Testing is necessary to ensure print requirements are achieved
- Ink adhesion, fastness (i.e., ability to maintain opacity or colour) and dry time need to be understood, based on substrate and ink design

Environment:

- Can function in environments up to IP65 with special protection
- Generally used in IP40 environments, making it suitable for low-dust and dry areas.
- See Section [8.2](#) for IP ratings

Maximum 2D barcode size:

- DoD (Piezo) printheads are available in heights of 35 mm, 50 mm, 72 mm and 144mm
- Printheads can be stacked to extend maximum height.
- Because a 2D barcode's data content can exceed individual printhead size capability, optimisation of data content is key.

X-dimension:

- Thanks to the high resolution of the DoD piezo printhead, GenSpecs 2D barcode X-dimensions are comfortably achievable

Substrates:

- There's no "ideal" DoD ink that works on every substrate
- The 5 ink types can adhere to most substrates

- Testing is necessary to ensure print requirements are achieved
- Ink adhesion, fastness (i.e., ability to maintain opacity or colour) and dry time need to be understood, based on substrate and ink design

Material/product handling (product moving):

DoD printheads should be **5 mm from the printed surface**. The distance from printhead to printed surface should not vary by more than +/- 2 mm. The printhead stand should be permanently mounted. The printhead holder should be 'keyed' or have locating features to ensure that its precise placement is repeatable, independent of operator.

- DoD (piezo) printheads should be **5 mm** from the printed surface
- Distance from printhead to printed surface should not vary by more than +/- 2 mm
- Printhead stand should be permanently mounted
- Printhead holder should be 'keyed' or have locating features to ensure repeatable, precise placement, independent of operator
- Printed surface must be perpendicular to the printhead's jet
- Print speed should be monitored via an encoder that is in a closed loop with the printer
- Dot (module) interspatial uniformity is determined by the moving speed of the printed surface, as well as by the line encoder.
- Conveyance of the printed surface must be smooth and free of vibration, to ensure dot (module) interspatial uniformity.

Material/product handling (printhead moving):

- **As above (product moving)**, but printhead stand is not permanently mounted
- Printing should be avoided during acceleration of the printhead, to ensure dot (module) interspatial uniformity.

Environmental considerations:

- DoD ink uses additives (both aqueous and non-aqueous) to maintain ink viscosity and expedite drying
- Solvents need to be handled in accordance with locally applicable VOC (volatile organic compound) regulations
- Gloves should be used when handling printheads.
- Regarding waste controls, disposal handling of DoD printheads needs to be considered, as these are not recyclable.

Quality control:

- Inline vision systems are used to validate 2D data content or verify specific print quality characteristics
- Can be augmented with periodic, offline verification (i.e., spot checks) of random samples.
- Printhead cleaning and wipe procedure need to be followed to avoid print degradation.

Challenges/Limitations

- Maximum DoD print speed determined by jetting capability of the printhead
- Maximum speed is ~ 60 m/min for High Quality (grade 3-4) barcodes.
- Print resolutions are either 300, 600 or 1200 dpi, which is not a limitation for 2D barcodes.
- Printer and printhead jet control and maintenance are important, as printhead jet clogging or malfunction ('jet out') can be caused by dirt or dried ink.
- The path of small ink drops can be unintentionally deviated by air currents (e.g., due to nearby fans or air conditioning ducts) or by static electricity.

- Care needs to be taken to avoid ink smearing due to unintentional contact with the printed surface before the printed ink has dried.
- Non-absorbent pre-treatment of the surface to be printed may be required for adhesion of ink to the printed surface.

8.1.4 Laser

Overview

Laser (Light Amplification by Stimulated Emission of Radiation) printing employs one of 3 methods:

- Ablation
- Engraving
- Thermochemical

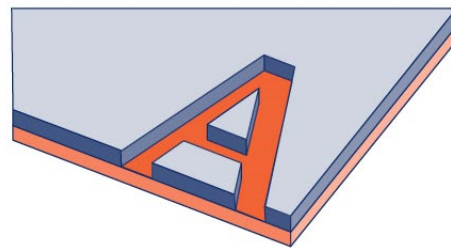

Figure 8-4 Ablation: controlled removal or ablation of material from a surface.

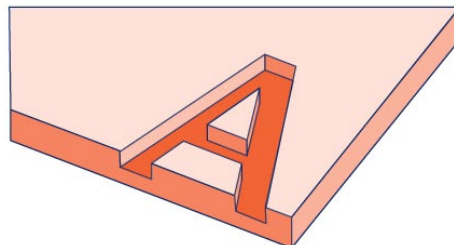

Figure 8-5 Engraving: precisely remove material from a surface.

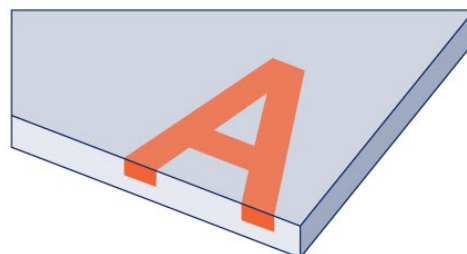

Figure 8-6 Thermochemical: combination of heat and chemical reactions induced by laser energy to alter the colour or properties of a material's surface.

Laser marking systems require a light source for direct marking of trade items; options include CO², Fiber/YAG, Diode, Green, and UV lasers. Each of these sources emits a distinct wavelength, carefully chosen for optimal interaction with various substrates. The light source is directed onto both stationary and moving elements, often facilitated by servo motors, which manipulate mirrors. These mirrors precisely steer the laser beam through a focusing lens onto the targeted substrate. Controlled modulation of the beam's on-and-off time empowers the laser, allowing it to scribe characters and 2D barcodes with precision and efficiency. The lens determines the focus point for the most efficient marking; this focus point determines the diameter of the laser's spot size.

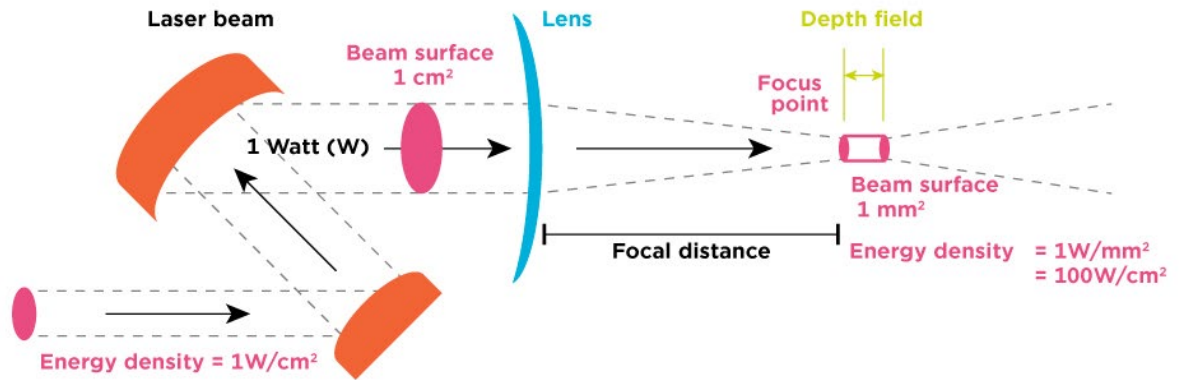

Figure 8-7 Example of a LASER source

Production:

Lasers are generally utilised in inline production applications, with moving products.

Technical overview (How It Prints):

Laser print resolution is 75-1200 dpi, determined by a combination of the lens and beam size.

Speed and quality for 2D barcodes:

- Laser printers have a maximum speed of 60 m/min for high-quality (ISO grade 3-4) 2D barcodes.
- Print quality is substrate- and process-dependent
- Type of laser should be selected based on substrate reaction to laser wavelength:
- **Ablation** removes layers of material (ink), exposing lower surfaces, and can generate 2D barcodes scannable by the majority of imaging scanners
- **Engraving** melts (plastics) or fractures (glass), creating groves or pockets in the substrate. The 2D created by engraving require specialised lighting and vision systems
- **Thermochemical** uses the reaction of a material within the substate (e.g., mica) or added to the surface (e.g., WBF, UVF). The contrast is often capable of being scanned by majority of imaging scanners

Maximum 2D barcode height:

- Laser printheads lens determines maximum height and width of 2D barcode.

Substrates and use cases:

- There is no "ideal" laser wavelength that works on every substrate
- Material marking performance is a function of laser wavelength, power and lens

Ablation and thermochemical reaction generate 2D barcodes with sufficient contrast and X-dimensions to be read by the majority of imaging scanners

Environment:

- Laser printers are capable of functioning in environments with up to IP66 (see Section [8.2](#) for IP ratings)
- Suitable for harsh application areas

Maximum 2D size and X-dimension:

- The laser's lens determines the maximum 2D size, X-dimension and other factors:
 - Product-to-laser marking distance (focal distance)
 - Acceptable variation in marking distance (depth of field)
 - Marking spot size (laser beam diameter) for X-dimension
 - Marking strength (energy density in W/mm³), calculated from the laser's base wattage per area (10 W, 30 W, 100 W, ...)
- Due to its small spot size, lasers can achieve the GenSpecs 2D barcode X-dimensions.

Material/product handling (product moving OR stationary):

- Laser printheads should be **5 mm** from the printed surface
- Distance from printhead to printed surface should not vary by more than +/- 2 mm
- Laser printhead distance to printed surface is determined by the specific lens. Variation of this distance depends on the lens' depth of field.
- Printhead stand should be permanently mounted
- Printhead holder should be 'keyed' or have locating features to ensure repeatable, precise placement, independent of operator
- Printed surface should be perpendicular to the printhead beam but **can be slightly off-perpendicular if the lens' depth of field allows for this**.
- Print speed should be monitored via an encoder that is in a closed loop with the printer
- The printed surface can be stationary, because the beam can be steered within a window that is determined by the mirror control and lens.
- Dot (module) interspatial uniformity is determined by the moving speed of the printed surface and by beam control.
- The printed surface must be free of vibration during printing.

Material/product handling (printhead moving):

- As above (product moving), but laser printheads generally do not move during printing, because laser sources are large and relatively heavy.

Environmental considerations:

- Guarding needs to be used to enclose the printer's laser and ensure that the beam cannot escape, to avoid any risk of injury (e.g., eye damage or burns).
- When working on printheads, technicians should wear special goggles designed specifically to block a laser's wavelength.
- Fume extraction is required to remove and filter smoke, particulates and harmful gases.

Quality control:

- Inline vision systems are used to validate 2D data content or verify specific print quality characteristics
- Can be augmented with periodic, offline verification (i.e., spot checks) of random samples.
- Lenses may need fume extraction or purged air to ensure beam consistency.

Challenges/Limitations

- High initial capital expenditure (CAPEX)
- Large printhead size may make integration challenging.

- Focal distance and material control can also be challenging.
- Different substrates react differently to specific wavelengths, with varying impacts on ink colour or ablation.
- Built up debris resulting from ablation needs to be managed / alleviated.
- Particular attention needs to be given to **beam control on high-speed applications**, because the laser can leave an unintentional 'tail mark' during the jump to new location.
- Safety considerations, including beam guarding and fume filtering, are extremely important.

8.1.5 Thermal transfer and direct thermal

Thermal transfer printing is a digital printing method that utilises pressure and heat to transfer ink from a ribbon onto a substrate, creating high-quality prints. Thermal transfer printers are used for film and label printing. The thermal printing on film is often referred to as thermal transfer overlay (TTO).

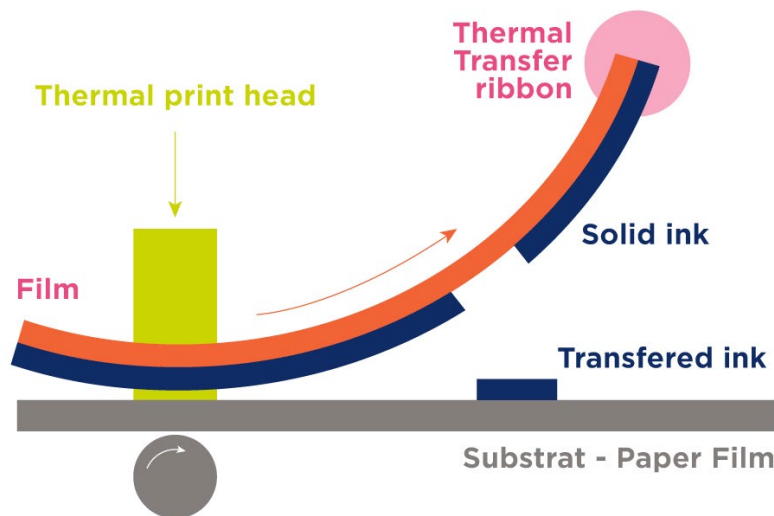

Figure 8-8 Example of a thermal transfer

Direct thermal is a type of printer that produces characters or 2D barcode on specially treated thermal paper without the need for ink, toner, or ribbons. The special thermal paper or label is coated with heat sensitive chemicals that changes colour when exposed to heat.

A thermal printhead has numerous tiny heating elements. These elements are arranged in a matrix and can generate 2D barcodes with precision.

Production:

- Thermal transfer and direct thermal are available as handheld, desktop and Print & Apply printing solutions
- Use both ribbon or direct thermal labels.
- Inline application use TTO (thermal transfer overprint) on flexible packaging (i.e., film) in a continuous or intermittent mode with ribbon

Speed and Quality for 2D barcodes:

- Thermal printers have a maximum speed of 45 m/min for high-quality (ISO grade 3-4) 2D barcodes.

Maximum 2D barcode height:

- Maximum matrix height is dependant printhead height.

Environment:

- Thermal transfer or direct thermal printers are capable of functioning in environments with up to IP65 with special protection.

Maximum 2D barcode size:

- Maximum 2D size for thermal transfer or direct thermal is dependent on printhead resolution and height
- For retail POS, the most popular TTO configurations are:
 - 203 dpi
 - 300 dpi
 - 600 dpi
 - 406 dpi is a less common option
- The most popular thermal printhead options are 2", 4", 5" and 6"
- Some manufacturers use 1" and 8" options

X-dimension:

- Thermal transfer or direct thermal X-dimension is determined by printhead dpi.
- To avoid module size issues, care must be taken match the dpi to the 2D X-dimension.

Substrates:

- Thermal transfer printers encompasses **3 basic types** of thermal printer ribbons available for printing on substrates.
 - **Full-wax ribbons** are the most common type of thermal transfer ribbon
 - Inexpensive, but less durable than other ribbons
 - Suited for barcode printing on coated and uncoated paper stock
 - Can hold up in indoor applications for short-term/temporary use.
 - **Wax-resin ribbons** fall into an intermediate price bracket
 - Suitable for printing barcodes on labels, including standard and weatherproof thermal transfer labels, as well as some flexible packaging types
 - Can withstand some degree of outdoor use, including exposure to moisture, abrasion, sunlight & moderate temperature changes
 - **Full-resin ribbons** are the most expensive & durable ribbon type
 - Suitable for printing barcodes on flexible packaging, textiles and other film applications
 - Can withstand moisture, abrasion, sunlight and extreme temperature changes.

Direct thermal uses labels, tags or paper usually made of paper or synthetic materials and are coated with a chemical layer that reacts to the heat from the thermal printhead, creating the printed content.

Material/product handling (product moving):

- Thermal Transfer Overlay (TTO) printhead and bracketry should be permanently mounted.
- Printhead holder should be 'keyed' or have locating features to ensure repeatable, precise placement, independent of operator
- One TTO printer can usually be configured for either continuous or intermittent printing.
 - **Continuous** TTO printheads employ a flexible film that continuously moves between platen roller and printhead.
 - **Intermittent** TTO printheads use flexible film indexes between platen pad and printhead.

- Film tension and perpendicular movement must be controlled to avoid tracking and printing problems (film creasing)
- An encoder is required to ensure that printhead ribbon speed is matched to film speed.

Material/product handling (printhead moving):

- The TTO printhead holder should be 'keyed' or have locating features to ensure that its precise placement is repeatable, independent of operator.
- Printing should be avoided during acceleration of the printhead.

Environmental considerations:

- Used TTO ribbon is not recyclable, although paper and plastic ribbon cores can be recycled.

Quality control:

- Inline vision systems are used to validate 2D data content or verify specific print quality characteristics
- Can be augmented with periodic, offline verification (i.e., spot checks) of random samples
- 2D error correction (ECC) helps maintain acceptable read rates.
- Printhead cleaning and wipe procedure need to be followed to avoid print degradation

Challenges/Limitations

- TTO maximum print speed is determined by printhead type and substrate.
- Maximum speed is ~ 45 m/min for High Quality (grade 3-4) 2D barcodes
- Higher speeds of 60 m/min might be possible.
- Print resolution of 203-600 dpi is not a limitation for 2D barcodes.
- Dusty or wet environments require additional enclosures and positive air pressure.
- Installation should be done by specially trained solution providers to ensure proper bracketry positioning and material movement.
- With regard to maintenance, printhead thermistors can fail and cause gaps (lines) in print.
- Adjusting 2D printing position in label design may prolong printhead life and avoid bad thermistors.
- Following solution providers' recommended printhead cleaning/maintenance schedule will help to maintain print quality.

Advantages

- Moderate capital expenditure (CAPEX)
- Low total cost of ownership (TCO).
- TTO printers are an excellent solution for flexible packing and labels.
- Ribbon adhesion solutions are available for most substrates.
- The wide TTO printhead can handle most content for the printed surface.
- TTO can print high quality 2D barcodes in any orientation.

8.1.6 Print and Apply (P&A)

Overview

Print and apply is type of labelling solution that overwhelmingly use thermal transfer and direct thermal printing systems described in Section [8.1.5](#) The key feature of this system is its **ability to print labels on demand and then automatically apply them to products or packages**. Print and Apply systems consist of a print engine controller, a dispenser/peeler module and a label applicator.

Print Engine and Controller:

The print engine is the part of the printer responsible for generating the printed content on the labels. It may include thermal print heads and rollers to facilitate the printing process. The printing process is usually thermal transfer ribbon onto labels or direct thermal labels. There are a few printhead designs that use TIJ and Piezo digital printing onto labels.

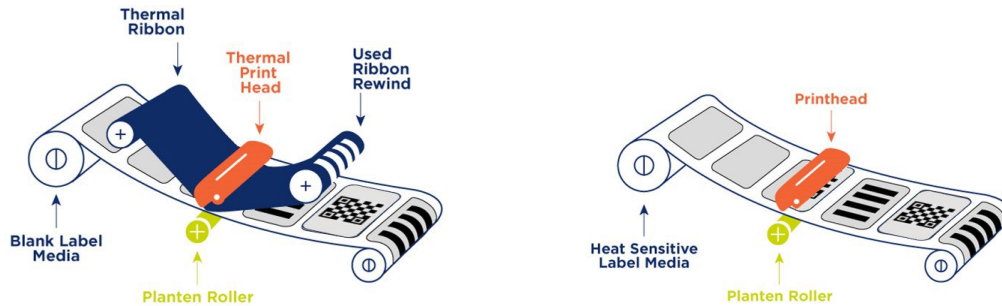

Figure 8-9 Example of thermal transfer and direct thermal label printing

The entire print and apply system is controlled by a central system, often integrated into the printer or a separate controller. It manages the printing parameters, label application timing, and coordination between the printer and applicator.

Dispenser/peeler module:

This module is designed to peel the label from its backing material, ensuring that the label is ready for application. It may use mechanisms such as vacuum or mechanical peeling to separate the label from its liner.

Label applicator:

The label applicator is responsible for applying the printed labels onto products or packages. The label applicator has a pad that usually use vacuum to hold the label whilst transfer it to the product or packaging. There are many label applicator designs, some of them use pneumatic or servo cylinders, blow applicator or wipe applicator to accurately apply the label to the target surface.

Speed and quality for 2D barcodes:

- Print and Apply printers speed is dependent on several factors, including but not limited to applicator type, printer use of a batch dispenser and the distance to the substrate
- High-quality grade (ISO grade 4) for 2D codes.

Maximum 2D barcode height:

- Size is dependent on the printhead resolution and width
- For retail POS, the most popular P&A configurations are:
 - 203 dpi
 - 300 dpi
 - 600 dpi
 - 406 dpi is a less common option

- The most popular thermal printhead options are 2", 4", 5" and 6"
- Some manufacturers use 1" and 8" options

X-dimension:

- Thermal transfer or direct thermal X-dimension is determined by the printhead dpi.
- To avoid module size issues, care must be taken match the dpi to the 2D X-dimension.

Substrates:**Labels**

- **Paper labels** are fairly inexpensive and commonly used type of material for general inventory, packaging and shipping labels, but tend to be less durable than other types.
 - Coated or uncoated labels
 - Coated labels are slightly more durable and resistant to tearing than uncoated
 - Gloss and matte coated papers
 - Glossy coatings are not commonly used because they reflect light and could distort a 2D barcode
- **Polypropylene labels**
 - Slightly more expensive durable label
 - Resistant to water and tearing
 - Not resistant to extreme weather or chemicals.
- **Polyester labels**
 - The most durable types of labels
 - Ideal choice for outdoor use, harsh conditions, or exposure to chemicals
 - Relatively rigid, making them **unsuitable for curved surfaces**
- **Polyethylene labels**
 - Less rigid material than polyester
 - **Ideal for use on curved surfaces**, such as bottles
 - Water- and chemical-resistant.
- **Polyimide labels**
 - Thermally stable plastic material that is designed for durability at temperature above 250 C
- **Vinyl labels:**
 - Often come with heavy duty adhesive designed for tamper-resistance
 - When attempting to remove, the label tears into small pieces.

Label liner

- **Paper liner** has a layer of silicone that allows the label adhesive to easily peel away from the liner. This layer of silicone on the label liner generally prevents it from being recyclable. Some solution providers offer recycling programs for the manufacture.
- **PET or Polyester liners** are more readily accepted into the recycling stream. However, it's not accepted universally, so solution providers offer recycling programs still tend to be the better option.

Ribbons

- Full wax ribbons
 - Most common type of thermal transfer ribbon.
 - Inexpensive, but less durable than other ribbons
 - Suited for barcode printing on coated and uncoated paper stock,

- Can hold up in indoor applications for short-term/temporary use.
- **Wax-resin ribbons**
 - Fall into an intermediate price bracket
 - Suitable for printing barcodes on labels, including standard and weatherproof thermal transfer labels, as well as some flexible packaging types.
 - Can withstand some degree of outdoor use, including exposure to moisture, abrasion, sunlight & moderate temperature changes.
- **Full-resin ribbons**
 - Most expensive & durable ribbon type
 - Suitable for printing barcodes on flexible packaging, textiles and other film applications
 - Can withstand moisture, abrasion, sunlight and extreme temperature changes.

Applicators

- Multiple designs for applicators range from a basic wipe to pneumatic or servo-driven versions
- Applicator and label pad are critical to the success (up-time and item per minute) of the P&A solution set
- The 4 major types of applicators are:
 - Blow
 - Wipe
 - Tamp
 - Corner wrap.
- Label pad can be made from soft rubber, plastic, or coated metals, and uses vacuum to hold the label in place until contacting the product.
- Applicator solutions must handle the product traversing speed, size or position variations (offsets)

Material/product handling (product moving or stationary):

- Labelling distance variation is dependent conveyor and product/case size
- Printhead stand should be permanently mounted
- Printhead holder should be 'keyed' or have locating features to ensure repeatable, precise placement, independent of operator
- Label application surface should be parallel or perpendicular applicator
- Product speed should be constant for repeatable label positioning
- Gaps need to be maintained for front or back side applications

Environmental considerations:

- Paper or plastic film maybe be recycled if local program exists

Quality control:

- Inline vision systems are used to validate 2D data content or verify specific print quality characteristics
- Can be augmented with periodic, offline verification (i.e., spot checks) of random samples.
- 2D error correction (ECC) helps maintain acceptable read rates.

Challenges/Limitations

- Maximum print speed limit determined by printhead type and label material
- Maximum speed is 24-45 m/min for High Quality (ISO grade 4.0) 2D barcodes.
- Print resolution of 203-600 is not a limitation for 2D barcodes.

- Maximum labelling speed is determined by distance to product and applicator design,
- Dusty or wet environments require additional enclosures and positive air pressure.
- Installation should be done by solution provider to ensure proper positioning and material movement.

Printhead and printer maintenance

- Printhead thermistors can fail and cause gaps (lines) in print.
- Adjusting 2D printing position in label design may prolong printhead life and avoid bad thermistors
- Following solution providers printhead cleaning/maintenance schedule will help to ensure print quality.

8.1.7 Digital printer

A digital production printer uses the piezo printheads and is a high-speed, high-volume printing device designed for producing large quantities of printed materials quickly and efficiently. Unlike traditional offset printing, digital production printing doesn't require the creation of printing plates, making it more adaptable for short print runs and variable data printing. Digital printers are often full colour printers leveraging CMYK ink, however specific ink colours are produced to align with manufacturer branding. The abbreviation CMYK refers to the four inks: cyan, magenta, yellow, and key (black). Digital printers have four main components:

1. Material input section:

This section is responsible for receiving aligning and preparing the substrate for printing. This could be managing the tension on a film, cleaning the substrate or adjusting the Dyne level to improve the ink adhesion for the printing process. Dyne level represents the force required to break the surface tension of a liquid across a material's surface. For example, corona or plasma flame treatment lower surface energy, for certain plastics and improve their "wettability" for the piezo applied inks.

2. Printing Engine:

The printing engine is the core of the printer, where the actual piezo printing process takes place. The printing engine translates the digital data into a visible print on paper, film or other printing materials. The print engine section also has the curing section. The inks used in digital printing often require a UV cure section to finish the ink bonding and fastness, improving the inks resistance to various environmental conditions.

3. Control Section:

The control section manages and coordinates the various components of the printer. It includes the printer's control panel, which allows users to interact with the device, set printing parameters, and monitor the printing process. This section is also responsible for the digital print quality control. High resolution cameras are used with software to look for imperfections, colour correctness (pantone match) and the data content including the 2D barcode's structure.

4. Output Section:

The output section handles the printed output once the printing process is complete. This section may include features like paper trays, finishing options (such as stapling, binding or cutting). Some commercial printers also have additional output options, such as sorting or collating.

These printers are used in commercial printing, publishing, and other industries where fast and flexible printing capabilities are crucial. They're now see applications on fast move consumer good production line where the product can be precisely controlled.

Production:

- Generally utilised in commercial printing application and some inline production applications with flat surfaces.

Inks:

- Digital printing inks are aqueous or UV-curable.

Technical overview (How It Prints):

- DoD print resolutions are 600-1200 dpi

Speed and quality for 2D barcodes:

- Maximum speed is ~ 70 m/min for high-quality (grade 4) 2D codes.

Maximum 2D barcode height:

- Maximum matrix height ranging from monochrome 50 mm (2") print width to full colour and up to 782mm (30.81")
- Suitable for retail and other sectors.

Substrates:

- **Rolls** and **sheets** are the two basic ways substrate material is delivered to the digital printing heads
- Example material for **rolls** includes, but is not limited to, fabric, labels, paper, polyester, polypropylene and vinyl
- Example material for **sheets** includes, but is not limited to, paper, poster stock, corrugated fibreboard and cardboard

Environment:

- Capable of functioning in environments with up to IP65 with special protection
- Generally, IP40, making it suitable for low dust and dry areas.

X-dimension:

- Due to the high printhead resolution of the piezo, the GenSpecs' 2D barcode X-dimensions are comfortably achievable.

Material/product handling (product moving):

- Digital printheads should be **5 mm** from the printed surface
- Distance from printhead to printed surface should not vary by more than +/- 2 mm
- Printhead stand should be permanently mounted
- Printhead holder should be 'keyed' or have locating features to ensure repeatable, precise placement, independent of operator
- Printed surface must be perpendicular to the printhead's jet
- Printhead speed should be monitored via an encoder that is in a closed loop with the printer
- Dot (module) interspatial uniformity is determined by the moving speed of the printed surface, as well as by the line encoder.
- Conveyance of the printed surface must be smooth and free of vibration, to ensure dot (module) interspatial uniformity.

Material/product handling (printhead moving):

- **As above (product moving)**, but printhead stand is not permanently mounted

Environmental considerations:

- Used ink is not recyclable
- UV cure ink can be harmful until cured

Quality control:

- Inline vision systems are used to validate 2D data content or verify specific print quality characteristics
- Can be augmented with periodic, offline verification (i.e., spot checks) of random samples.
- Printhead cleaning and wipe procedure need to be followed to avoid print degradation.



Challenges/Limitations



- Maximum digital print speed is determined by the jetting capability of the printhead
- Maximum speed is ~ 70 m/min for High Quality (grade 4) barcodes.
- Print resolutions are either 600 or 1200 dpi. This is not a limitation for 2D barcodes.
- Printer and printhead jet control and maintenance are important, as printhead jet clogging or malfunction ('jet out') can be caused by dirt or dried ink.
- The path of small ink drops can be unintentionally deviated by air currents (e.g., due to nearby fans or air conditioning ducts) or by static electricity.
- Care needs to be taken to avoid ink smearing due to unintentional contact with the printed surface before the printed ink has dried.
- Non-absorbent pre-treatment of the surface to be printed may be required for adhesion of ink to the printed surface.
- Dry time can vary, so care needs to be taken to ensure that ink does not come into contact with another surface while still wet.

8.1.8 Printing summary

There are many solution provider printer manufacturing companies producing quality printing equipment. The table below does not represent the latest high-speed versions or older less capable printers. It's important to note that these are general ranges, and ratings may differ based on the specific model and manufacturer. This table is only an indication of the average printers and their capability to print 2D barcodes.

Table 8-1 Summary of average printing speed for 18x18 Data Matrix

Technology	Average printing speed for an 18X18 matrix	Print quality range	Actual 18X18 matrix print example (Data content not important)
Continuous Ink Jet (CIJ)	~45m/minute	2.0 to 3.0	
Thermal Ink Jet (TIJ)	~60m/minute	3.0 to 4.0	
Thermal Transfer (TT) (label or film)	~45m/minute	3.0 to 4.0	

Technology	Average printing speed for an 18X18 matrix	Print quality range	Actual 18X18 matrix print example (Data content not important)
Laser (CO ² 30W)	~60m/minute	3.0 to 4.0	
Digital Printing (Piezo)	~60m/minute	3.0 to 4.0	

8.2 IP rating

An ingress protection (IP) rating is a standard defined by the International Electrotechnical Commission (IEC) that classifies and rates the degree of protection provided by mechanical casings and electrical enclosures against the intrusion of solid objects, like dust, and liquids, such as water.

The IP rating is typically written as "IP" followed by two digits (e.g., IP65). The first digit refers to the level of protection against solid objects, and the second digit indicates the level of protection against liquids.

1. First Digit (Protection against Solid Objects):

- 0: No protection
- 1: Protection against solid objects larger than 50mm (e.g., a hand)
- 2: Protection against solid objects larger than 12.5mm (e.g., fingers)
- 3: Protection against solid objects larger than 2.5mm (e.g., tools and wires)
- 4: Protection against solid objects larger than 1mm (e.g., small tools and wires)
- 5: Limited protection against dust ingress (dust-protected)
- 6: Complete protection against dust ingress (dust-tight)

2. Second Digit (Protection against Liquids):

- 0: No protection
- 1: Protection against vertically falling drops of water
- 2: Protection against vertically falling drops of water when tilted up to 15 degrees
- 3: Protection against spraying water at an angle up to 60 degrees from vertical
- 4: Protection against water splashing from any direction
- 5: Protection against water jets (limited ingress permitted)
- 6: Protection against powerful water jets (limited ingress permitted)
- 7: Protection against the effects of temporary immersion in water (up to 1 meter for 30 minutes)
- 8: Protection against continuous immersion in water under conditions specified by the manufacturer

For example, an IP65 rating indicates a high level of protection against both dust (6) and water (5), making a device dust-tight and capable of water jets.

8.3 2D barcode encoding modes

GS1 DataMatrix, Data Matrix and QR Code support different encoding modes (e.g., numeric, alphanumeric, binary, and Kanji). Choosing the mode that best suits the type of data being encoded can minimise the size. In many cases, barcode creation software will automatically identify and use the encoding option most efficient for the entered data.

By choosing the appropriate encoding mode for the data, it can optimise the barcode size. For example:

- If the data primarily consists of numbers, using the numeric encoding mode can result in a more compact barcode.
- If the data includes a combination of numbers and letters, the alphanumeric encoding mode might be more efficient than binary mode.
- 2D barcodes encoding can also include mixed mode encoding, however one needs to be aware that mode switches require characters to identify the change in modes and therefore increase the total encoding.

8.3.1 GS1 DataMatrix and Data Matrix (GS1 Digital Link URI) modes

- **Text Encoding Mode:** This mode is used to encode numeric data. It is particularly suitable for encoding sequences of digits. (3.3bits/character)
- **Binary Encoding Mode:** This mode is used to encode binary data, including 8-bit binary values. (8 bits/character)
- **C40 Encoding Mode:** This mode is designed to efficiently encode alphanumeric characters and control characters. It uses a compact binary representation that allows for more data to be encoded in a smaller space. (various bit lengths depending on the specific character, but ~5.3 bits/character)
- **ASCII Mode:** In this mode, each character is encoded using its ASCII value. This includes alphanumeric characters, punctuation, and control characters. The ASCII mode can represent up to 128 different characters. (~8 bits/character)
- **ECI Mode (Extended Channel Interpretation):** ECI mode allows specifying additional character encodings and languages beyond the standard character sets. It enables compatibility with various character encoding standards. (bit length/character varies),
- **Kanji mode:** This mode allows for compression of Shift-JIS wide character byte sequences into a smaller number of codewords. (~13bit/character)
- **X12 & EDIFACT Mode:** X12 is a specific encoding mode used for encoding data in the context of EDI (Electronic Data Interchange) messages, and the EDIFACT mode is used for encoding data in the context of EDI messages but follows the EDIFACT standard which are both commonly used in business transactions.
- **Base 256 Encoding Mode:** This mode is used for encoding binary data such as images, audio, or other types of binary files. It uses a more efficient binary encoding scheme.

These encoding modes allow GS1 DataMatrix and Data Matrix to accommodate a wide range of data types and formats, making it a versatile choice for various applications such as product labelling, tracking, and data storage. The choice of encoding mode depends on the type of data being encoded and the desired level of encoding efficiency.

8.3.2 QR Code (GS1 Digital Link URI) modes

- **Binary/byte mode:** This mode is used to encode binary data, including 8-bit binary values. (8 bits/character)
- **Numeric mode:** Supports digits 0-9 only and achieves around 3.32 bits/digit (~4bit/character), presumably through encoding a numeric string as an integer value
- **Alphanumeric mode supports the following characters:** 0-9 A-Z (uppercase only) space \$ % * + - . / : and achieves 5.5 bits/character (~6bit/character), - comparable with URN Code 40 (C40) but supporting slightly more symbol characters (space \$ % * + / are not supported in the basic version of C40)
 - Key problem is lack of lowercase. No more efficient mode than Byte mode for lowercase.
- **Kanji mode:** This allows for compression of Shift-JIS wide character byte sequences into a smaller number of codewords. (~13bit/character)
- **ECI Mode (Extended Channel Interpretation):** ECI mode allows specifying additional character encodings and languages beyond the standard character sets. It enables compatibility with various character encoding standards. (bit length/character varies), Mode:

- Designed for numeric data (0-9)
- More efficient for encoding numeric strings
- Each digit is represented by a smaller number of bits compared to alphanumeric or binary encoding

9 Contributors

Thank you to all the contributors who dedicated their time, expertise, and insights to the development of this *2D Barcodes at Retail Point-of-Sale Implementation Guideline*. Your valuable contributions have played a pivotal role in shaping this comprehensive resource.

Name	Organisation
Sprague Ackley	Digimarc
Makoto Akutagawa	GS1 Japan
Pete Alvarez	GS1 Global Office
Jonathan Anderson	Polytag
Anette Andersson	ICA Sverige AB
Jonas Andersson	Ikea
Nicolas Andrieu	ARMOR SAS
Albert Ang	GS1 Global Office
Phil Archer	GS1 Global Office
Karen Arkesteyn	GS1 Belgium & Luxembourg
Stefan Artlich	Bayer AG - Division Pharma
Debby Atallah	GS1 Canada
Sarah Atkins	GS1 UK
Andrea Ausili	GS1 Italy
Xavier Barras	GS1 France
Jonas Batt	GS1 Switzerland
Toni Baxter Juenger	Procter & Gamble Co.
Brian Becker	Wegmans Food Markets
Robert Beideman	GS1 Global Office
Dieter Beitz	CSB-System SE
Zaid Ben Hmad	DECATHLON
Laura Merce Bermudez	GS1 UK
Marc Blanchet	Viagenie
Angela Bohn	Johnson & Johnson
Vincent Branquet	GS1 France
Laure Breduilleard Brunet (co-chair sub-team)	Nestlé

Name	Organisation
Emma-Michaela Brind	GS1 UK
Scott Brown	1WorldSync, Inc.
David Buckley	GS1 Global Office
Heide Buhl	GS1 Germany
Marie Burnay	GS1 Global Office
Terry Burton	Terry Burton Consulting Ltd
Silvio Calado	GS1 Brasil
Elena Campdelacreu	GS1 Spain
Emanuela Casalini	GS1 Italy
Martin Catalano	GS1 Argentina
Tony Ceder	Charmingtrim
Madalina Cernat	GS1 Romania
Jiraporn Chalermjirarat	GS1 Thailand
Anthony Chan	GS1 Hong Kong, China
Kitty Chan	GS1 Hong Kong, China
Lincoln Chan	GS1 Hong Kong, China
Hammond Chen	GS1 China
Tony Chen	GS1 Chinese Taipei
Mignone Cheng	GS1 Hong Kong, China
Xavier Cheynet	Blédina SA
Raman Chhima	GS1 New Zealand
James Chronowski	GS1 US
Pavla Cihlarova	GS1 Czech Republic
Brian Cook (co-chair sub-team)	Polytag
Flavia Costa	GS1 Brasil
Luiz Costa	GS1 Brasil
Deirdre Courtney	GS1 Global Office
Jeffrey Cree	Ahold (USA)
Jay Crowley	US Data Management, LLC (USDm)
Oscar Cruz	GS1 Mexico
Stefan Dahlgren	ICA Sverige AB
Tarryn Daniels	GS1 South Africa
Peter Davenport	GS1 Australia

Name	Organisation
Donna Debenham	Mondelez International
Frank Debusmann	REA Elektronik GmbH
Johan den Engelse	GS1 Netherlands
Sean Dennison	GS1 Ireland
Herve d'Halluin	DECATHLON
Peta Ding (editor)	GS1 Global Office
Mark Dingley	Matthews Australasia Pty Ltd
Volker Ditscher	WIPOTEC-OCS GmbH
Kevin Dixie	Buyerdock Ltd
Dounya Djellouli	GS1 Algeria
Deniss Dobrovolskis	H&M group
Xiaowen Dong	GS1 China
Marcel Ducceschi	Migros-Genossenschafts-Bund
Jeanne Duckett	Avery Dennison RFID
Jared Dyson	Wal-Mart Stores, Inc.
Judit Egri	GS1 Hungary
Emmanuel Ekuma	GS1 Nigeria
Sarah Ellenbogen	Digiphy
Fadi El-Turk	GS1 UK
Christophe Elyn	Groupe Seb France
Melissa Emma	Nestle Coffee Partners
Umit Erinc	Migros Ticaret
Lautaro Escudero	GS1 Argentina
Rachel Fonck	Blédina SA
Piotr Frackowiak	GS1 Poland
Guido Freijomil	GS1 Argentina
Stefan Gathmann	GS1 Ireland
Eleanor Gayle	GS1 Global Office
Fabiano Gemignani	GS1 Brasil
Jean-Christophe Gilbert	GS1 France
Paula Giovannetti	EC Workshops, LLC
Sébastien Girondon	Catalina
Chiang Fein Goh	GS1 Malaysia



Name	Organisation
Nicole Golestani	GS1 Canada
Juan Pablo Gomez Sepulveda	GS1 Mexico
Harshal Gore	GS1 Canada
Adeline Grare	Savencia
Nadi (Scott) Gray	GS1 Global Office
Neil Gray	GS1 UK
Gerald Gruber	GS1 Austria
Steve Gryczka	Markem-Imaje Corporation
Marina Guegan	Carrefour
Dominique Guinard	Digimarc
Rami Habbal	GS1 UAE
Jason Hale	GS1 UK
Carla Hamrick	Coca-Cola Company (The)
Gary Hartley	GS1 New Zealand
Andrew Hearn	GS1 Global Office
Olle Hellman	GS1 Sweden
Harshal Hiray	Wal-Mart Stores, Inc.
Sandra Hohenecker	GS1 Germany
David Holliday (co-chair sub-team)	ProMach, Inc.
Pierre-Arnaud Hommel	ARMOR SAS
On Pui Hong	GS1 Hong Kong, China
Michelle Hood	Wal-Mart Stores, Inc.
Jessica Horst	The J.M. Smucker Company
Scott Howarth	Sinclair Systems International
Ibrahim Hoxha	HOXHA
José Ramón Islas	GS1 Mexico
Michelle Isley	The J.M. Smucker Company
Yoshihiko Iwasaki	GS1 Japan
Darek Jadczyk	GS1 Poland
Caroline James	GS1 New Zealand
Yohan Jeon	GS1 Korea
Patrik Jonasson	GS1 Global Office
Nora Kaci	GS1 Global Office

Name	Organisation
Ethem Kamanli	Migros Ticaret
Iliada Karali	GS1 Association Greece
Roula Karam	Antares Vision
Velin Karchev	GS1 Bulgaria
Volkan Kavsak	GS1 Germany
Steven Keddie (lead editor)	GS1 Global Office
Jennifer Keegan	Woolworths Limited
Audrey Kelly	GS1 Global Office
Kimmo Keravuori	GS1 Finland
Mads Kibsgaard	GS1 Denmark
Anna Klapper	Videojet Technologies
Jean-Marc Klopfenstein	Nestlé
Anilcan Kocaman	Migros Ticaret
Valerie Koeberlé	Nestlé France SAS
Cihan Korucu	GS1 Türkiye
Christian Lauer	GS1 Austria
Lorna Leaver	GS1 UK
Guillaume Ledeun	GS1 France
Mark Lee	GS1 Singapore
Jerome Lemay	DECATHLON
Leong Leon	GS1 Malaysia
Kathy Leski	SGK
Carsten Leutloff	SPECTARIS e.V.
Piergiorgio Licciardello	GS1 Global Office
Ildikó Lieber	GS1 in Europe
Rubens Lima	GS1 Brasil
Anna Lin	GS1 Hong Kong, China
Nicolas Liou	GS1 Chinese Taipei
Gregg London	U.P.C. Data Market
Wayne Luk	GS1 Hong Kong, China
Craig MacDougall	DoD
Ilka Machemer	GS1 Germany
Richard Manaton	GS1 New Zealand

Name	Organisation
Alessandro Mastrogiovanni	Emmi Schweiz AG
Cady McMaster	Wegmans Food Markets
Riad Mechtari	GS1 Algeria
Terje Menkerud	GS1 Norway
Joel Meyer	Digimarc
Dibyajeeban Mishra	DECATHLON
Ephraim Mokheseng	GS1 South Africa
Adrien Molines	GS1 France
Philippe Montoulieu	FROMARSAC SAS
Julie Moore	Mead Westvaco
Nicolas Mordacq	Dentsu Aegis Network
Andrew Morehead	GS1 US
Gena Morgan	GS1 US
Kerry Morrison	GS1 UK
Lynn Mount	Nestlé (US)
Sabri Mourad	Markem-Imaje Corporation
Alice Mukaru	GS1 Sweden
Dan Mullen (editor)	GS1 Global Office
Hirokazu Nagai	Japan Pallet Rental Corporation
Arif Naikwade	H&M group
Safae Nassih	GS1 France
Steven Nelson	Tyson
Cam Ha Nguyen Thi	GS1 Vietnam
Rebecca Nichols	Wakefern Food Corporation
Jeff Nolan	Automatic Identification Systems, Inc. (AIS)
Sara Novak	Kenvue
Babatunde Odunlami	GS1 Nigeria
Roberto Olivares (co-chair)	Woolworths Limited
Garance Osternaud	Carrefour
Michel Ottiker (co-chair)	GS1 Switzerland
Sait Ozkan	Domino UK Limited
SILVÉRIO PAIXÃO	GS1 Australia
Chensheng Pan	GS1 China

Name	Organisation
Luis Paniagua	GS1 Costa Rica
Manos Papadakis	GS1 Association Greece
Alessandra Parisi	GS1 Brasil
Kyle Parker	Mitas Corporation
Aydin Parmaksiz	Migros Ticaret
Sergio Pastrana	GS1 Mexico
Nicolas Pauvre	GS1 France
John Pearce	Axicon
Mahardhika Derana Perkasa	GS1 Indonesia
Mayurintr Petchad	GS1 Thailand
Sara Petersson	GS1 Sweden
Olivier Pichon de Bury	Catalina
Sarina Pielaat	GS1 Netherlands
Neil Piper	GS1 Global Office
John Pitts	Antares Vision
Etienne POT	GS1 France
Haris Poturković	GS1 Bosnia and Herzegovina
Olivier Poulizac	ARMOR SAS
Muriha Qidwai	EON Group Holdings Inc.
Jiangfeng Qiu	GS1 China
Matheus Quadros	GS1 Brasil
Maximilian Rams	GS1 Germany
Aruna Ravikumar (co-chair sub-team)	GS1 Australia
Edna Melissa Reina Calderon	Logyca
Amy Reiter	GS1 US
Craig Alan Repec (editor)	GS1 Global Office
Nicolas Resier	GS1 Belgium & Luxembourg
Mohamed Riaz	3M Healthcare
Sylvia Rubio Alegren	ICA Sverige AB
Zbigniew Rusinek	GS1 Poland
John Ryu (facilitator)	GS1 Global Office
Zbigniew SAGAN	Advanced Track and Trace
Sofia Salcedo	Logyca

Name	Organisation
Roxana Saravia Bulmini	GS1 Argentina
Hans Peter Scheidt	C&A SCS
Kelly Schlafman (co-chair)	Procter & Gamble Co.
Andrea Schlossarek	METRO Group
Sue Schmid	GS1 Australia
Tom Eric Schmidt	August Storck KG
Lori Schrop	GS1 Global Office
Nicolas Seguin	ARMOR SAS
Eugen Sehorz	GS1 Austria
Bernard Shen	Bayer AG - Division Pharma
Xinyu Shi	GS1 China
Yuko Shimizu	GS1 Japan
Catherine Siah	GS1 Singapore
Fernando Silveira	GS1 Brasil
Chumisa Sizathu	GS1 South Africa
Tania Snioch	GS1 Global Office
Kai-Wing So	GS1 Belgium & Luxembourg
Roko Staničić	GS1 Slovenia
Andrew Steele	GS1 Australia
Jo Anna Stewart	GS1 US
Jean Stifle	Beam Suntory Inc
Jennie Stitzinger	GS1 US
Daniel Stojcevic	SPAR Management AG
Henrik Stubbans	GS1 Sweden
Christa Suc	GS1 UK
Xiaoyun Sun	GS1 China
Mouhammad Takieddin	Procter & Gamble Co.
Arvo Tambek	GS1 Estonia
Claude Tetelin	GS1 Global Office
Marianne Timmons	GS1 Global Office
Ann Tindale	GS1 Australia
Elena Tomanovich	GS1 Global Office
Gina Tomassi	PepsiCo, Inc.

Name	Organisation
Dominic Tong	GS1 Hong Kong, China
Laurent Tonnelier	mobiLead
Viet Tran	GS1 Vietnam
Sophie Tron	GOTOIoT
Jangchup Tsechung	Migros-Genossenschafts-Bund
Alec Tubridy	GS1 Ireland
Vivian Underwood	GS1 US
James Urquhart	GS1 US
Jeroen van Rosmalen	Amgen Inc.
Stephanie van Rossum	GS1 Global Office
Sébastien Vanneau	L'Oreal France
Ray Vaughan	Omron Microscan Systems Inc.
Mauricio Vazquez	Colgate-Pamolive
Luciano Véliz	GS1 Chile
Andrew Verb	Bar Code Graphics, Inc.
Jon Verb	Bar Code Graphics, Inc.
Ricardo Verza Amaral Melo	GS1 Brasil
Sam von Bose	Wal-Mart Stores, Inc.
Kana Wakebe	GS1 Japan
Hanna Walczak	GS1 Poland
Amber Walls (co-chair)	GS1 US
Chunguang Wang	GS1 China
Jiayi Wang	GS1 China
Lei Wang	GS1 China
Wenyu Wang	GS1 China
Metinee Wanlayangkoon	GS1 Thailand
Wilfried Weigelt	REA Elektronik GmbH
Beth Wells	GS1 US
Carrie Wen	GS1 Chinese Taipei
George Wright IV	Product Identification & Processing Systems
Kevin Wu	Creative Sensor Inc.
XinMin WU	GS1 China
Huang Xin	GS1 China

Name	Organisation
Ruoyun Yan	GS1 China
Yanyan Yang	GS1 France
Qilei Yin	GS1 China
Shi Yu	Beijing REN JU ZHI HUI Technology Co. Ltd.
Christian Zaeske	METRO Group
Yanis Zhi	GS1 China
Elisa Zwaneveld	GS1 Global Office

10 References

Document	Author
2D in Retail co-located test results	GS1 GO GSMP, Inc.
GS1 Barcode Syntax Resource	GS1 GO GSMP, Inc.
Best practices for creating your QR Code powered by GS1	GS1 GO GSMP, Inc.
Connecting barcodes to related information	GS1 GO GSMP, Inc.
Electronic Product Code Information Services	GS1 GO GSMP, Inc.
EPCIS for event data	GS1 GO GSMP, Inc.
EPC/RFID standards	GS1 GO GSMP, Inc.
GS1 2D in retail barcodes explorer	GS1 GO GSMP, Inc.
GS1 case study library	GS1 GO GSMP, Inc.
GS1-Conformant Resolver Standard	GS1 GO GSMP, Inc.
GS1 DataMatrix Guideline	GS1 GO GSMP, Inc.
GS1 DataMatrix Position Paper	GS1 GO GSMP, Inc.
GS1 Digital Link quick start guide	GS1 GO GSMP, Inc.
GS1 Digital Link URI Standard	GS1 GO GSMP, Inc.
GS1 Electronic Data Interchange	GS1 GO GSMP, Inc.
GS1 General Specifications	GS1 GO GSMP, Inc.
GS1 Global Data Model	GS1 GO GSMP, Inc.
GS1 Global Data Synchronisation Network	GS1 GO GSMP, Inc.
GS1 Module Count tool	GS1 GO GSMP, Inc.
GS1 Web Vocabulary	GS1 GO GSMP, Inc.
GS1 two-dimensional (2D) barcodes	GS1 GO GSMP, Inc.
GTIN Management Standard	GS1 GO GSMP, Inc.
Introduction to QR Codes	Digital.gov
ISO/IEC 15415: Information technology; automatic identification and data capture techniques; bar code print quality test specification; two-dimensional symbols	ISO/IEC JTC1/SC31
ISO/IEC 15416: Information technology; automatic identification and data capture techniques; bar code print quality test specification; linear symbols	ISO/IEC JTC1/SC31



Document	Author
ISO/IEC 16022 Information technology – Automatic identification and data capture techniques – Data Matrix barcode symbology specification	ISO/IEC JTC1/SC31
ISO/IEC 18004 Information technology – Automatic identification and data capture techniques – QR Code barcode symbology specification	ISO/IEC JTC1/SC31
Security considerations for QR Codes	Canadian Centre for Cyber Security
The key role of GS1 DataMatrix barcodes for product identification in healthcare.	GS1 GO GSMP, Inc.
Verified by GS1	GS1 GO GSMP, Inc.
www.gs1.org/glossary	GS1 GO GSMP, Inc.